



**BLP-E**  
**ELECTRIC FLOOR MODEL BRAISING PAN WITH**  
**ELECTRIC POWER TILT**  
**INSTALLATION – OPERATION – MAINTENANCE**



**BLODGETT OVEN COMPANY**

[www.blodgett.com](http://www.blodgett.com)  
44 Lakeside Avenue, Burlington, Vermont 05401 USA Telephone (800) 331-5842, (802) 860-3700 Fax: (802) 864-0183

S00068 Rev A (7/04)

## **IMPORTANT NOTES FOR INSTALLATION AND OPERATION**

It is recommended that this manual be read thoroughly and that all instructions be followed carefully. This manual should be retained for future reference.



**This is the safety alert symbol. It is used to alert you to potential personal injury hazards. Obey all safety messages that follow this symbol to avoid possible injury or death.**

**Adequate clearances must be maintained for servicing and proper operation.**



**WARNING: Improper installation, operation, adjustment, alteration, service or maintenance can cause property damage, injury or death. Read the installation, operating and maintenance instructions thoroughly before installing, operating or servicing this equipment.**

**This manual should be retained for future reference.**

**Intended for commercial use only. Not for household use.**

## **TABLE OF CONTENTS**

<b>DESCRIPTION</b>	<b>PAGE</b>
1.0 Important Notes for Installation and Operation	2
2.0 Service Connections	4
3.0 Installation Instructions	5
4.0 Operation Instructions	8
5.0 Cleaning Instructions	10
6.0 Cooking Guidelines	11
7.0 Maintenance	15
8.0 Troubleshooting	16

## 2.0 SERVICE CONNECTIONS

 Single electrical connection required for 208, 240 or 480 volt, single or three phase 60Hz. with ground wire.

 COLD WATER: 3/8" O.D. tubing to faucet (OPTIONAL)

 HOT WATER: 3/8" O.D. tubing to faucet (OPTIONAL)

Available kW			AMPS PER LINE								
MODEL	STD.	OPT.	kW	PHASE	208V	220V	240V	380V	415V	480V	600V
BLP-30E	12	N/A	12	1	57.7	54.5	50.0	N/A	N/A	N/A	N/A
				3	33.3	31.5	28.9	18.2	16.7	14.4	11.5
BLP-40E	15	18	15	1	72.1	68.2	62.5	N/A	N/A	N/A	N/A
				3	41.6	39.4	36.1	22.8	20.9	18.0	14.4
			18	1	86.5	81.8	75.0	N/A	N/A	N/A	N/A
				3	50.0	47.2	43.3	27.3	25.0	21.7	17.3

### DIMENSIONS

MODEL	CAPACITY	UNITS	A	B	C
BLP-30E	30 gallons	inches	36.0	33.5	74
	114 litres	mm	914	851	1880
BLP-40E	40 gallons	inches	48.0	45.5	74
	152 litres	mm	1219	1156	1880

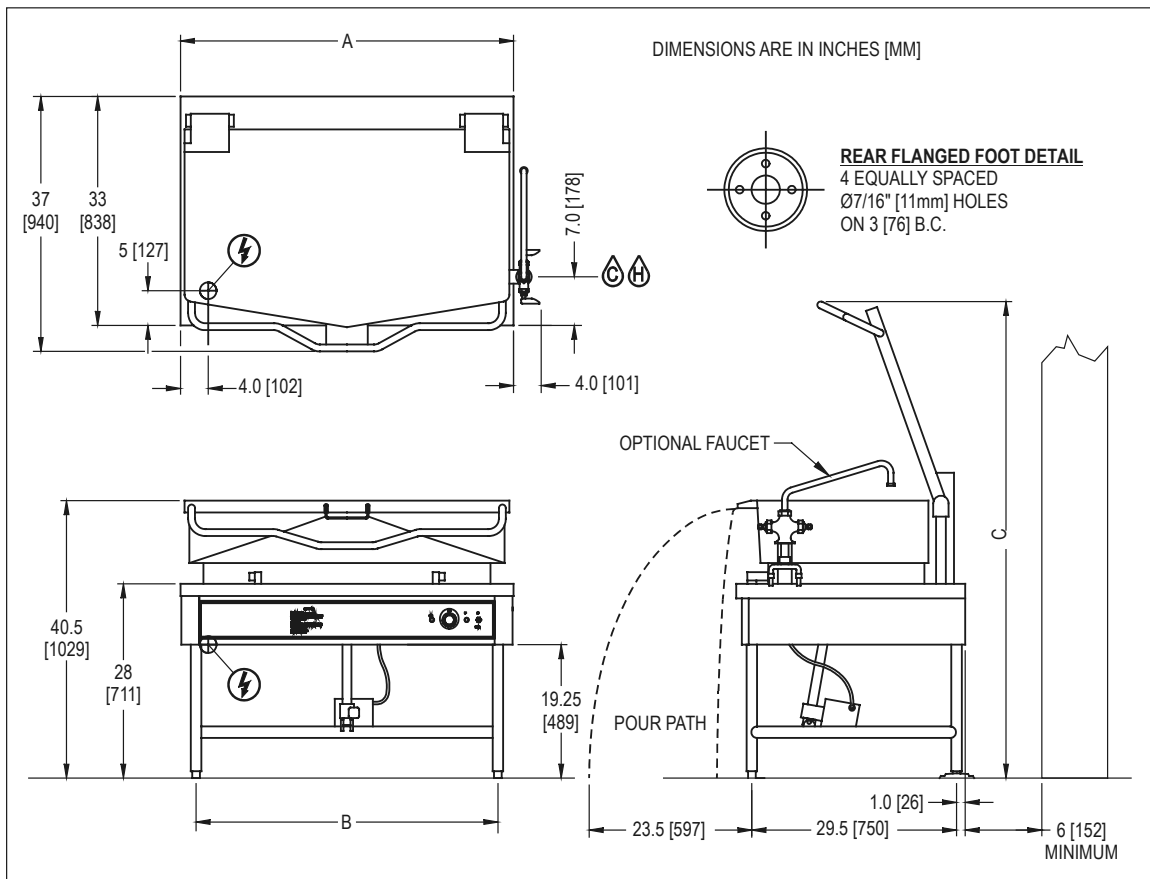

### **3.0 INSTALLATION INSTRUCTIONS**

#### **UNPACKING**

Immediately after unpacking, check for possible shipping damage. If the tilting braising pan is found to be damaged, save the packaging material and contact the carrier within 15 days of delivery.

Before installing, verify that the electrical service agrees with the specifications on the rating plate located on the left side panel as you face the front of the braising pan. If the supply and equipment requirements do not agree, contact your dealer or Blodgett.

#### **LOCATION**

The installation location must allow adequate clearances for servicing and proper operation. A minimum front clearance of 36", and rear clearance of 6" is required.

#### **INSTALLATION CODES AND STANDARDS**

Your Blodgett Tilting Braising Pan must be installed in accordance with:

1. In the U.S.A. installation must comply with state and local codes, or in the absence of local codes, with the National Electrical Code ANSI/NFPA-70 (latest edition). In Canada installation must comply with Provincial and local codes, or in the absence of local codes, with: C.S.A. C22.1 Canadian Electrical Code, Part 1.
2. ANSI NFPA Standard #96, "Vapor Removal from Cooking Equipment," (latest edition), available from the National Fire Protection Association, Batterymarch Park, Quincy, MA 02269.

## **LEVELING AND ANCHORING TILTING BRAISING PAN**

1. Place tilting braising pan in the installation position.
2. Place a carpenter's level on top of the braising pan and turn the adjustable feet to level braising pan side-to-side and front-to-back.
3. Mark hole locations on the floor through the anchoring holes provided in the rear flanged adjustable feet.
4. Remove tilting braising pan from installation position and drill holes in locations marked on the floor. (See installation diagram on page 4.) Insert proper anchoring devices (not supplied).
5. Place tilting braising pan back in the installation position.
6. Place carpenter's level on top of braising pan and re-level side-to-side and front-to-back.
7. Bolt and anchor tilting braising pan securely to the floor.
8. Seal bolts and flanged feet with silastic or equivalent compound.

## **ELECTRICAL CONNECTIONS**

	<b>WARNING: Electrical and grounding connections must comply with the applicable portions of the National Electrical Code and/or other local codes.</b>
---	---

	<b>WARNING: Before performing any maintenance disconnect the electrical power supply and place a tag at the disconnect switch to indicate that you are working on the circuit.</b>
---	--

The wiring compartment is located behind the control panel. Refer to Page 4 Service Connections.

1. Remove the wiring compartment cover and make electrical connections per the wiring diagram located inside the control housing cover panel. (The braising pan must be grounded in accordance with requirements of the National Electrical Code or applicable local codes.) See warning (page 6). Connection from incoming lines must be waterproof.
2. Ground skillet to terminal provided in control housing. A wiring diagram is provided and is located inside the control cover panel.
3. Replace wiring compartment cover.

## **SERVICE CONNECTIONS**

All internal wiring for the skillet is complete.

Make service connections as indicated on page 4 and electrical connections above.

If a faucet is provided, connect the water supplies and check for proper operation.

## 4.0 OPERATION INSTRUCTIONS

	<b>WARNING:</b> The tilting braising pan and its parts are hot. Use care when operating, cleaning and servicing the tilting braising pan.
--	---

### BEFORE FIRST USE

Using a non-corrosive, grease-dissolving commercial cleaner, clean the protective metal oils from all surface parts and the interior of the tilting braising pan. Follow the cleaner manufacturer's directions. Rinse thoroughly and drain the pan. Wipe dry with a soft clean cloth.

### CONTROLS

- Red Temperature Light** - Illuminates when heating elements are supplying heat to the tilting braising pan.
- Thermostat**
  - Turns tilting braising pan ON and maintains set temperature by controlling power supply. Temperature settings are marked on the control panel in either °C or °F.
- Tilt Switch**
  - Push UP to raise tilting braising pan; push DOWN to lower tilting braising pan.

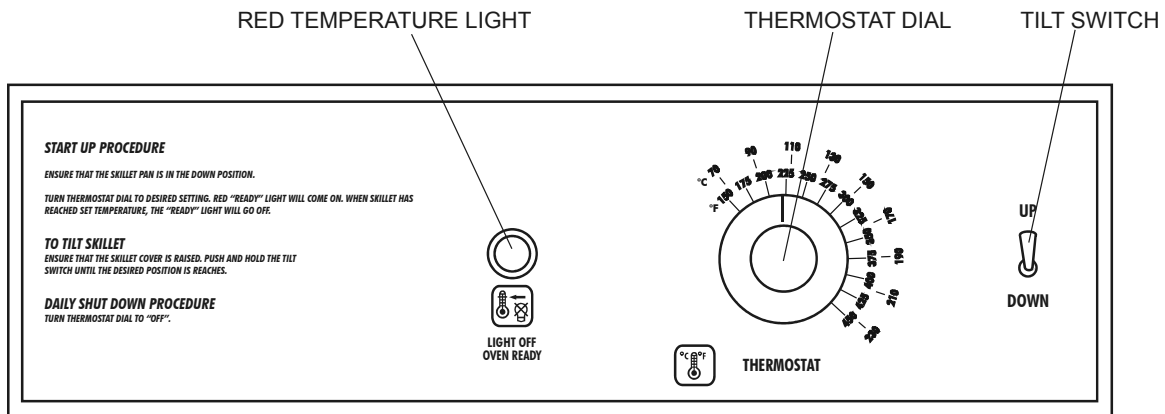

FIGURE 1

## **START-UP PROCEDURE**

1. Ensure that the braising pan is in the DOWN position.
2. Turn THERMOSTAT dial to desired temperature (reference Cooking Guidelines, Page 11). The red TEMPERATURE light will come on.
3. When braising pan has reached set temperature, the red TEMPERATURE light will go off and the heating elements will shut off. The heating elements will cycle on and off thereafter to maintain set temperature. The red TEMPERATURE light will cycle on and off with the heating elements.
4. Preheat braising pan and allow it to cycle to equalize heat across the entire surface.
5. Water will boil faster with the lid down.
6. Turn THERMOSTAT to OFF when braising pan is not in use.

## **DAILY SHUTDOWN PROCEDURE**

To turn tilting braising pan off, turn THERMOSTAT dial to OFF.

1. DO NOT try to tilt braising pan with lid down.
2. Make sure the receiving pan is in place.
3. To tilt braising pan, push and hold TILT SWITCH in the UP mode until desired pan position has been reached. The braising pan will empty when raised to the top tilt position.
4. When the braising pan is raised 5° or more, the heating elements will be turned off automatically.
5. Food is poured through the removable strainer into a food receiving pan positioned under the lip of the pouring spout (Figure 2).
6. To lower braising pan, push and hold TILT SWITCH in the DOWN mode.

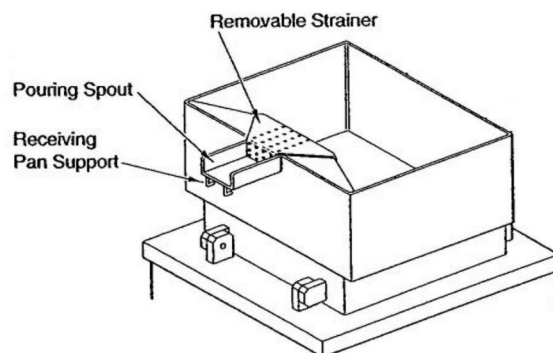

**FIGURE 2**

#### NOTE

**Excessive, consecutive lifts may cause the motor to overheat and activate the thermal overload causing the motor to shut down.**

**Should this occur, a cooling off time will be necessary to reset and continue the lifting operation.**

#### 5.0 CLEANING INSTRUCTIONS



**WARNING: Disconnect electrical power supply before cleaning.**

Before cleaning allow the tilting braising pan to cool and then clean it. Keep exposed cleanable areas of the tilting braising pan clean at all times. Do not get water in electrical box or any electrical component.

1. Thoroughly wash pan, pouring spout (see Figure 2), lid and exterior surfaces with detergent and warm water. If necessary, soak pan to remove food that is stuck to pan surface. Rinse thoroughly and wipe dry with a soft clean cloth.
2. Clean removable strainer and receiving pan support (Figure 2) with detergent and warm water. Rinse thoroughly and wipe dry with a soft clean cloth.

## 6.0 COOKING GUIDELINES

The guidelines given below are suggested quantities, temperature settings, and **estimated** numbers of orders per load and per hour. When two temperatures are given, the first is to start the product, and the second to finish the product.

The following temperatures should be used:

	<u>Temperature (°F)</u>
Simmering	200 Maximum
Sautéing	225 - 275
Searing	300 - 350
Frying	325 - 375
Grilling	350 - 450

<u>ITEM</u>	<u>PORTION</u>	<u>TEMP (F)</u>	<u>BATCH/HR</u>	<u>BLP-30E PER LOAD QTY</u>	<u>BLP-30E PER LOAD PORTIONS</u>	<u>BLP-40E PER LOAD QTY</u>	<u>BLP-40E PER LOAD PORTIONS</u>
<b>BREAKFAST FOODS</b>							
Bacon	3 slices	350	12	2 lbs.	10	3 lbs.	15
Eggs							
- Boiled-Hard	1 egg	225	5	50 eggs	50	75 eggs	75
- Boiled-Soft	1 egg	225	8	50 eggs	50	75 eggs	75
- Fried	1 egg	400	4	30 eggs	30	45 eggs	45
- Poached	1 egg	225	5	36 eggs	36	60 eggs	60
- Scrambled	1-1/2 eggs	300-200	1	18 gal.	720	28 gal.	1100
French Toast	3 slices	450	7	35 slices	12	50 slices	17
Regular Oatmeal	½ cup	250	2	20 lbs. (100 cups)	500	40 lbs. (200 cups)	1000
Pancakes	2 each	400	10	30 ea.	15	50 ea.	25
<b>FISH</b>							
Clams	1 pt.	400	10	10 qts.	20	15 qts.	30
Fish Cakes	2 - 3 oz.	400	5	70 - 3 oz.	35	110 - 3 oz.	55
Haddock Fillet	4 oz.	400	4	60 - 4 oz.	60	90 - 4 oz.	90
Halibut Steak	5 oz.	450	3	60 - 4 oz.	60	90 - 4 oz.	90
Lobster	1 - 1 lb.	350	4	20 - 1 lb.	20	30 - 1 lb.	30
Swordfish	5 oz.	450	3	50 - 5 oz.	50	75 - 5 oz.	75

<u>ITEM</u>	<u>PORTION</u>	<u>TEMP (F)</u>	<u>BATCH/HR</u>	<u>BLP-30E PER LOAD</u>		<u>BLP-40E PER LOAD</u>	
				<u>QTY</u>	<u>PORTIONS</u>	<u>QTY</u>	<u>PORTIONS</u>
<b>SAUCES, GRAVIES, SOUPS</b>							
Brown Gravy	1 oz.	350 - 200	2	18 gal.	2300	35 gal.	4500
Cream Sauce	2 oz.	250 - 175	1	18 gal.	1150	35 gal.	2250
Cream Soup	6 oz.	200	1	18 gal.	375	35 gal.	725
French Onion Soup	6 oz.	225	1	18 gal.	350	35 gal.	700
Meat Sauce	4 oz.	350 - 200	1	18 gal.	575	35 gal.	1100
<b>VEGETABLES</b>							
<b><u>CANNED</u></b>	3 oz.	400	6	30 lbs.	125	45 lbs.	200
<b><u>FRESH</u></b>							
Beans, Wax, Green	3 oz.	400	3	25 lbs.	125	50 lbs.	250
Beets	3 oz.	400	1	30 lbs.	125	60 lbs.	300
Broccoli	3 oz.	400	3	25 lbs.	125	40 lbs.	200
Cabbage	3 oz.	400	5	20 lbs.	80	30 lbs.	125
Carrots	3 oz.	400	2	35 lbs.	150	70 lbs.	300
Cauliflower	3 oz.	250	5	15 lbs.	75	25 lbs.	125
Corn	1 ear	400	8	50 ears	50	75 ears	75
Potatoes	3 oz.	400	2	40 lbs.	200	60 lbs.	300
Spinach	4 oz.	250	10	6 lbs.	25	9 lbs.	35
Turnips	4 oz.	400	2	20 lbs.	100	30 lbs.	150
<b><u>FROZEN</u></b>							
Beans, French Green	3 oz.	400	6	15 lbs.	60	22-1/2 lbs.	90
Lima Beans	3 oz.	250	4	15 lbs.	60	22-1/2 lbs.	90
Broccoli	3 oz.	400	8	12 lbs.	50	18 lbs.	75
Sliced Carrots	3 oz.	250	6	15 lbs.	60	22-1/2 lbs.	90
Small Whole Carrots	3 oz.	250	3	15 lbs.	50	22-1/2 lbs.	90
Corn	3 oz.	250	18	15 lbs.	50	22-1/2 lbs.	90
Small Whole Onions	3 oz.	250	7	15 lbs.	50	22-1/2 lbs.	90
Peas	3 oz.	400	10	15 lbs.	75	22-1/2 lbs.	110
Spinach	3 oz.	400	3	15 lbs.	75	22-1/2 lbs.	110

<u>ITEM</u>	<u>PORTION</u>	<u>TEMP (F)</u>	<u>BATCH/HR</u>	<u>BLP-30E PER LOAD</u>		<u>BLP-40E PER LOAD</u>	
				<u>QTY</u>	<u>PORTIONS</u>	<u>QTY</u>	<u>PORTIONS</u>
<b>DESSERTS, PUDDINGS, SWEET SAUCES</b>							
Butterscotch Sauce	1 oz.	200	1	18 gal.	2300	35 gal.	4500
Cherry Cobbler	3 oz.	200	1	18 gal.	750	35 gal.	1500
Chocolate Sauce	1 oz.	200	1	18 gal.	2300	35 gal.	4500
Cornstarch Pudding	4 oz.	200	1	18 gal.	575	35 gal.	1100
Fruit Gelatin	3 oz.	250	2	18 gal.	750	35 gal.	1500
<b>MEAT-POULTRY</b>							
Bacon	3 slices	350	12	2 lbs.	10	3 lbs.	15
<b><u>BEEF</u></b>							
Amer. Chop Suey	6 oz.	400 - 225	2	18 gal.	350	35 gal.	700
Beef Stew	8 oz.	300	-	18 gal.	280	35 gal.	560
Corned Beef Hash	5 oz.	400	5	16 lbs.	50	25 lbs.	75
Cheeseburger	3 oz.	300	12	7 lbs.	35	10 lbs.	50
Hamburger	3 oz.	300	15	7 lbs.	35	10 lbs.	50
Meatballs	1 oz.	400-225	3	12-1/2 lbs.	65	18 lbs.	100
Pot Roast	2 oz.	350-200		120 lbs.	500	180 lbs.	750
Salisbury Steak	5 oz.	400	3	16 lbs.	50	24 lbs.	75
Sirloin Steak	6 oz.	400	5	15 lbs.	40	22-1/2 lbs.	60
Swiss Steak	4 oz.	300-200	1	25 lbs.	110	40 lbs.	160
<b><u>CHICKEN</u></b>							
Pan Fried	2-1/4's	350	3	50 pieces	25	80 pieces	40
Whole	2 oz.	350-200		16 - 5 lbs.	200	24-5 lbs.	265
<b><u>FRANKFURTERS</u></b>							
Grilled	2 oz.	300	8	22 lbs.	176	33 lbs.	264
Boiled	2 oz.	250	12	16 lbs.	128	25 lbs.	200
<b><u>PORK</u></b>							
Ham Steak	3 oz.	400	8	10 lbs.	50	15 lbs.	75
Sausage Links	3 links	350	7	30 lbs.	120	45 lbs.	180
Pork Chops	5 oz.	350	4	15 lbs.	50	25 lbs.	75

<u>ITEM</u>	<u>PORTION</u>	<u>TEMP (F)</u>	<u>BATCH/HR</u>	<u>BLP-30E PER LOAD</u>		<u>BLP-40E PER LOAD</u>	
				<u>QTY</u>	<u>PORTIONS</u>	<u>QTY</u>	<u>PORTIONS</u>
<b>MEAT-POULTRY (continued)</b>							
<b><u>TURKEY</u></b>							
Off Carcass	2 oz.	400-200	–	3 26-30 lbs.	200	4 26-30 lbs.	275
On Carcass	2 oz.	400-200	–	4 16-20 lbs.	175	6 16-20 lbs.	265
<b>MISCELLANEOUS</b>							
Grilled Cheese Sandwich	1 sandwich	400	8	35 sandwiches	35	50 sand.	50
Macaroni & Cheese	8 oz.	200	2	18 gal.	300	35 gal.	525
Rice	4 oz.	350-225	1	20 lbs. raw	320	40 lbs. raw	650
Spaghetti	4 oz.	350-225	2	8 lbs. raw	200	12 lbs. raw	300

## 7.0 MAINTENANCE



**WARNING:** The tilting braising pan and its parts are hot. Use care when operating, cleaning and servicing the tilting braising pan.



**WARNING:** Disconnect electrical power supply and place a tag at the disconnect switch to indicate that you are working on the circuit before performing any maintenance.

## ADJUSTMENTS

All tilting braising pans are adjusted at the factory.

At least twice a year, have an authorized service person clean and adjust the tilting braising pan for maximum performance.

## **8.0 TROUBLESHOOTING**

### **HEATING ELEMENTS DO NOT COME ON:**

1. Power supply not "ON".
2. Pan not in down position.
3. Defective thermostat or elements.
4. Defective limit switch or activator mechanism.
5. Defective contactors.

### **PAN WILL NOT OPERATE (UP OR DOWN):**

1. Power supply not "ON".
2. Motor has overheated and thermal overload has shut down motor. Wait 15 to 20 minutes and try again.

The gear reducer is sealed and permanently lubricated with a high grade synthetic grease.

### **IMPORTANT NOTICE:**

Your skillet is equipped with a thermally protected motor which raises and lowers the pan. Continuous operation of 8 or more cycles may cause the motor to overheat and shut down. Should this occur wait approximately 15 to 20 minutes for motor to cool. Motor should then be ready for operation. To avoid this occurring DO NOT run motor continuously for more than a few cycles.