



KPT/KLT-DS Series

DIRECT STEAM TILTING FLOOR KETTLE

INSTALLATION - OPERATION - MAINTENANCE



BLODGETT OVEN COMPANY

www.blodgett.com
44 Lakeside Avenue, Burlington, Vermont 05401 USA
Manufacture Service Questions: 866-518-3977

PART NUMBER 170099 REV B (04/11)

THIS MANUAL MUST BE RETAINED FOR FUTURE REFERENCE. READ, UNDERSTAND AND FOLLOW THE INSTRUCTIONS AND WARNINGS CONTAINED IN THIS MANUAL.

FOR YOUR SAFETY

DO NOT STORE OR USE GASOLINE OR OTHER FLAMMABLE VAPORS AND LIQUIDS IN THE VICINITY OF THIS OR ANY OTHER APPLIANCE.

WARNING

IMPROPER INSTALLATION, ADJUSTMENT, ALTERATION, SERVICE OR MAINTENANCE CAN CAUSE PROPERTY DAMAGE, INJURY OR DEATH. READ THE INSTALLATION, OPERATING AND MAINTENANCE INSTRUCTIONS THOROUGHLY BEFORE INSTALLING OR SERVICING THIS EQUIPMENT.

NOTIFY CARRIER OF DAMAGE AT ONCE

IT IS THE RESPONSIBILITY OF THE CONSIGNEE TO INSPECT THE CONTAINER UPON RECEIPT OF SAME AND TO DETERMINE THE POSSIBILITY OF ANY DAMAGE, INCLUDING CONCEALED DAMAGE. WE SUGGEST THAT IF YOU ARE SUSPICIOUS OF DAMAGE TO MAKE A NOTATION ON THE DELIVERY RECEIPT. IT WILL BE THE RESPONSIBILITY OF THE CONSIGNEE TO FILE A CLAIM WITH THE CARRIER. WE RECOMMEND THAT YOU DO SO AT ONCE.

IMPORTANT - READ FIRST - IMPORTANT

- CAUTION:** BE SURE ALL OPERATORS READ, UNDERSTAND AND FOLLOW THE OPERATING INSTRUCTIONS, CAUTIONS, AND SAFETY INSTRUCTIONS CONTAINED IN THIS MANUAL.
- WARNING:** THIS UNIT IS INTENDED FOR USE IN THE COMMERCIAL HEATING, COOKING AND HOLDING OF WATER AND FOOD PRODUCTS, PER THE INSTRUCTIONS CONTAINED IN THIS MANUAL. ANY OTHER USE COULD RESULT IN SERIOUS PERSONAL INJURY OR DAMAGE TO THE EQUIPMENT AND WILL VOID WARRANTY.
- CAUTION:** SHIPPING STRAPS ARE UNDER TENSION AND CAN SNAP BACK WHEN CUT.
- CAUTION:** UNIT WEIGHS 190 TO 270 LBS (85 TO 125 KG). FOR SAFE HANDLING, INSTALLER SHOULD GET HELP AS NEEDED, OR USE MATERIALS HANDLING EQUIPMENT (E.G., FORK LIFT, DOLLY OR PALLET JACK) TO REMOVE THE UNIT FROM THE SKID AND MOVE IT TO THE PLACE OF INSTALLATION.
- WARNING:** KETTLES MUST BE INSTALLED BY PERSONNEL QUALIFIED TO WORK WITH PLUMBING. IMPROPER INSTALLATION CAN RESULT IN INJURY TO PERSONNEL AND/OR DAMAGE TO EQUIPMENT.
- WARNING:** AVOID ANY EXPOSURE TO ESCAPING STEAM. STEAM CAN CAUSE SEVERE BURNS.
- WARNING:** TAKE EXTREME CARE TO KEEP HOT CONTENTS FROM SPILLING OR SPLASHING ON ANYONE. DO NOT STAND DIRECTLY IN FRONT OF KETTLE BODIES WHEN THEY ARE BEING TILTED.
- WARNING:** AVOID ALL DIRECT CONTACT WITH HOT EQUIPMENT SURFACES. DIRECT SKIN CONTACT COULD RESULT IN SEVERE BURNS.
- WARNING:** AVOID ALL DIRECT CONTACT WITH HOT FOOD OR WATER IN KETTLES. DIRECT CONTACT COULD RESULT IN SEVERE BURNS.
- CAUTION:** DO NOT OVER FILL THE KETTLE WHEN COOKING, HOLDING OR CLEANING. KEEP LIQUIDS A MINIMUM OF 2-3" (5-8 cm) BELOW THE KETTLE BODY RIM TO ALLOW CLEARANCE FOR STIRRING, BOILING AND SAFE PRODUCT TRANSFER.
- WARNING:** TAKE SPECIAL CARE TO AVOID CONTACT WITH HOT KETTLE BODY OR HOT PRODUCT WHEN ADDING INGREDIENTS, STIRRING OR TRANSFERRING PRODUCT TO ANOTHER CONTAINER.
- WARNING:** WHEN TILTING KETTLE FOR PRODUCT TRANSFER:
- 1) WEAR PROTECTIVE OVEN MITT AND PROTECTIVE APRON.
 - 2) USE CONTAINER DEEP ENOUGH TO CONTAIN AND MINIMIZE PRODUCT SPLASHING.
 - 3) PLACE CONTAINER ON STABLE, FLAT SURFACE, AS CLOSE TO KETTLE AS POSSIBLE.
 - 4) STAND TO LEFT OR RIGHT SIDE OF KETTLE (DEPENDING ON TILTING HANDLE PLACEMENT) WHILE POURING. DO NOT STAND DIRECTLY IN POUR PATH OF HOT CONTENTS.
 - 5) POUR SLOWLY, MAINTAIN CONTROL OF KETTLE BODY HANDLE AT ALL TIMES, AND RETURN KETTLE BODY TO UPRIGHT POSITION AFTER CONTAINER IS FILLED OR TRANSFER IS COMPLETE.
 - 6) DO NOT OVERFILL CONTAINER. AVOID DIRECT SKIN CONTACT WITH HOT CONTAINER AND ITS CONTENTS.

IMPORTANT - READ FIRST - IMPORTANT

- CAUTION:** KEEP FLOORS IN FRONT OF KETTLE WORK AREA CLEAN AND DRY. IF SPILLS OCCUR, CLEAN IMMEDIATELY, TO AVOID SLIPS OR FALLS.
- WARNING:** FAILURE TO CHECK SAFETY VALVE OPERATION PERIODICALLY COULD RESULT IN PERSONAL INJURY AND/OR DAMAGE TO EQUIPMENT.
- WARNING:** WHEN TESTING, AVOID ANY EXPOSURE TO THE STEAM BLOWING OUT OF THE SAFETY VALVE. DIRECT CONTACT COULD RESULT IN SEVERE BURNS.
- WARNING:** TO AVOID INJURY, READ AND FOLLOW ALL PRECAUTIONS STATED ON THE LABEL OF THE WATER TREATMENT COMPOUND.
- CAUTION:** MOST CLEANERS ARE HARMFUL TO THE SKIN, EYES, MUCOUS MEMBRANES AND CLOTHING. PRECAUTIONS SHOULD BE TAKEN. WEAR RUBBER GLOVES, GOGGLES OR FACE SHIELD AND PROTECTIVE CLOTHING. CAREFULLY READ THE WARNINGS AND FOLLOW THE DIRECTIONS ON THE LABEL OF THE CLEANER TO BE USED.
- CAUTION:** USE OF ANY REPLACEMENT PARTS OTHER THAN THOSE SUPPLIED BY THE MANUFACTURER OR ITS AUTHORIZED DISTRIBUTORS CAN CAUSE OPERATOR INJURY AND DAMAGE TO THE EQUIPMENT, AND WILL VOID ALL WARRANTIES.
- IMPORTANT:** SERVICE PERFORMED BY OTHER THAN FACTORY AUTHORIZED PERSONNEL WILL VOID WARRANTIES.

Table of Contents

Important Operator Warnings.....	page 1-2
References.....	page 3
Equipment Description.....	page 4-5
Inspection & Unpacking.....	page 6
Installation	page 7
Initial Start-Up.....	page 8
Operation	page 9
Sequence of Operation	page 10
Maintenance.....	page 11
Cleaning.....	page 12-13
Troubleshooting.....	page 14
Parts List.....	page 15
Bucket Steam Trap.....	page 16
Service Log	page 17

References

KLENZADE SALES CENTER ECOLAB. Inc.
370 Wabasha St. Pau , Minnesota 55102
800/352-5326 or 612/293-2233

NSF INTERNATIONAL
789 N. Dixboro Road
P.O. Box 130140
Ann Arbor, Michigan 48113-0140

ZEP MANUFACTURING CO.
1310-T Seaboard Industrial Blvd.
Atlanta, Georgia 30318

Equipment Description

The Blodgett KLT/KPT series are deep type, tilting kettles with direct steam-heated 2/3 jackets. The stainless steel kettles have welded, reinforced rims and butterfly shaped pouring lips. The liner and pouring lip of all kettles are 316 stainless steel. They are ASME shop-inspected, and are registered with the National Board. The kettles have a 180 emery grit interior finish and a bright semi-deluxe exterior finish.

Every unit requires a remote steam source. The steam supply is controlled by an inlet valve, and enters the jacket through one trunnion directly into the jacket. Steam pressure forces condensate out a dip tube through the other trunnion. Both steam and condensate lines are concealed within the support structures of the various models. The table at bottom right shows the standard kettle sizes for each model.

These kettles operate safely and efficiently at various steam pressures above five PSI, with upper pressure limits assured by the provided safety valve. Operation also requires a globe valve on the steam inlet and a strainer, steam trap, and check valve on the condensate outlet. These may be ordered as optional equipment.

Kettles are emptied by tilting, but optional tangent draw-offs are available. The standard draw-off is two inch outer diameter stainless steel, with compression disc valve and a removable stainless steel strainer that has 1/4 inch perforations. Strainers with 1/8 inch or no perforations are also available. The table on the bottom right shows the sizes of draw-offs which can be furnished with each model.

The kettles in this series employ a worm and gear tilting mechanism, which is completely enclosed.

The kettles are mounted in two ways. The KPT Model is suspended in a stainless steel yoke on a pedestal base. The outer circumference of the base is flanged down for proper sealing to the floor. The KLT Model is supported by a tubular, stainless steel tri-leg frame with adjustable floor flanges.

Options include:

1. Lift-off cover (for kettles smaller than 60 gallons)
2. Cover with counter-balancing actuator (for 40 gallon and larger kettles)
3. Fill faucets with swing spout
4. Basket cooking system
5. Kettle brush kit
6. Operating pressures up to 90 PSIG

Equipment Description

MODEL	Kettle Capacity	Inside Diameter	Rim Height	Overall Width	Front-to-Back	Base Style
20DS-KPT	20 Gallons 75 liters	20 inches 508 mm	36 inches 914 mm	36-1/4 inches 921 mm	23 inches 584 mm	Yoke & Pedestal
40DS-KPT	40 Gallons 150 liters	26 inches 660 mm	38-1/2 inches 978 mm	43 inches 1092 mm	30 inches 762 mm	Yoke & Pedestal
60DS-KPT	60 Gallons 225 liters	30 inches 762 mm	43 inches 1092 mm	47 inches 1194 mm	34 inches 864 mm	Yoke & Pedestal
20DS-KLT	20 Gallons 75 liters	20 inches 508 mm	36 inches 914 mm	36-1/4 inches 921 mm	29 inches 737 mm	Tubular Leg
40DS-KLT	40 Gallons 150 liters	26 inches 660 mm	36 inches 914 mm	43 inches 1092 mm	34-1/2 inches 870 mm	Tubular Leg
60DS-KLT	60 Gallons 225 liters	30 inches 762 mm	44 inches 1118 mm	47 inches 1194 mm	38-1/4 972 mm	Tubular Leg
80DS-KLT	80 Gallons 300 liters	32 inches 813 mm	48 inches 1219 mm	49 inches 1245 mm	39-1/4 inches 997 mm	Tubular Leg

Inspection & Unpacking

CAUTION
AVOID NAILS AND SPLINTERS WHEN REMOVING KETTLES FROM WOODEN CRATES. WEAR SAFETY GLASSES.

CAUTION
SHIPPING STRAPS ARE UNDER TENSION AND CAN SNAP BACK WHEN CUT.

CAUTION
UNIT WEIGHS 215 TO 295 LBS (98 TO 134 KG). FOR SAFE HANDLING, INSTALLER SHOULD GET HELP AS NEEDED, OR USE MATERIALS HANDLING EQUIPMENT (e.g., FORK LIFT, DOLLY OR PALLET JACK) TO REMOVE THE UNIT FROM THE SKID AND PLACE IT FOR INSTALLATION.

The kettle will arrive completely assembled and wrapped in protective plastic, strapped and bolted on a heavy skid, enclosed in a three-wall cardboard crate. (80 gallon and larger kettles are in wooden crates.) Immediately on receipt remove the box and plastic wrap, and inspect the unit for damage. Report any damage or an incorrect shipment to the delivery agent.

Write down the model number, serial number and installation date, and keep this information for future reference. Space for these entries is provided at the top of the Service Log in the back of this manual.

When installation is to begin, cut the straps holding the unit on the skid. Lift the unit straight up off of the skid.

Installation

WARNING
THIS UNIT MUST BE INSTALLED BY PERSONNEL QUALIFIED TO WORK WITH PLUMBING. IMPROPER INSTALLATION CAN CAUSE INJURY TO PERSONNEL AND/OR DAMAGE TO EQUIPMENT.

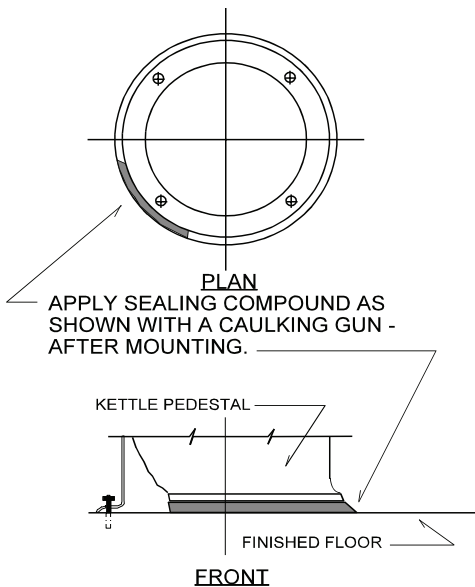

For proper sanitation, a continuous seal is required between pedestals or flanges and the mounting surface.

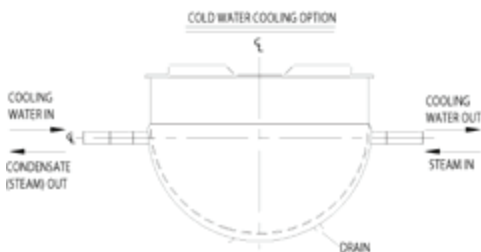

Cold water cooling option.

All Models

1. Installation under a ventilation hood is recommended. Consult local codes.
2. Install and anchor the kettle on a level surface.
3. If the steam supply pressure is greater than the maximum working pressure stamped on the nameplate, you must install a pressure reducing valve in the steam supply line near the kettle.
4. Connect the steam supply line to the steam inlet fitting. Include a steam control valve and an appropriate safety valve. To obtain the full heating capability of the kettle, the steam supply line must be as large as the steam inlet fitting.
5. The safety valve is preset to relieve jacket pressure that exceeds its rated limit. Do not try to adjust the valve setting, and do not allow the valve outlet or lever to be blocked.
6. Connect the kettle condensate return line to the boiler return line, or to a drain. A suitable steam trap, strainer, and check valve must be installed.
7. Any mechanical change must be approved by the Food Service Engineering Department.

Floor-Mounted Models

1. Install the unit on a level surface. Ensure that there is adequate clearance at the sides and rear, as required by the specification drawings. Anchor the pedestal or legs securely to the floor.
2. Apply a continuous bead of clear silicone sealant (No. 732 or equivalent) to the junction between the pedestal or leg flange and the surface, as shown in the illustration at left. Fill all cracks and crevices, and wipe excess away.

Initial Start-Up

IMPORTANT
BE SURE ALL OPERATORS READ,
UNDERSTAND AND FOLLOW THE OPERATING
INSTRUCTIONS, CAUTIONS, AND SAFETY
INSTRUCTIONS CONTAINED IN THIS MANUAL.

WARNING
AVOID EXPOSURE TO ESCAPING STEAM,
WHICH CAN CAUSE SEVERE BURNS.



Now that the kettle has been installed, you should test it to ensure that it is operating correctly.

1. Remove all literature and packing materials from inside and outside of the unit.
2. Pour a small amount of water into the kettle.
3. Open the steam inlet valve.
4. When the water begins to boil, inspect all of the fittings to ensure that there are no leaks.
5. Check the safety valve by pulling out on its chain, (or lifting its lever on older models) far enough to let steam escape. Then let it snap back into place to reseal the valve so that it will not leak.
6. Shut down the unit by closing the steam inlet valve.
7. Operate the tilting mechanism and draw-off valve to confirm that they function through the whole range of normal operation.

If the unit functions as described above, it is ready for use. If the unit does not function as intended, contact your local Certified Service Agency.

Operation

WARNING
AVOID EXPOSURE TO ESCAPING STEAM,
WHICH CAN CAUSE SEVERE BURNS.

WARNING
AVOID ALL DIRECT CONTACT WITH HOT
FOOD OR WATER IN THE KETTLE. DIRECT
CONTACT COULD RESULT IN SEVERE BURNS.
TAKE SPECIAL CARE TO AVOID CONTACT
WITH HOT KETTLE BODY OR HOT PRODUCT,
WHEN ADDING INGREDIENTS, STIRRING OR
TRANSFERRING PRODUCT TO
ANOTHER CONTAINER.

CAUTION
DO NOT OVERFILL THE KETTLE WHEN
COOKING, HOLDING OR CLEANING. KEEP
LIQUIDS AT LEAST 2-3" (5-8 cm) BELOW
THE KETTLE BODY RIM TO ALLOW
CLEARANCE FOR STIRRING, BOILING
PRODUCT AND SAFE TRANSFER.

WARNING
WHEN TILTING KETTLE FOR PRODUCT
FOR PRODUCT TRANSFER:

- 1) WEAR PROTECTIVE OVEN MITT AND PROTECTIVE APRON.
- 2) USE CONTAINER DEEP ENOUGH TO CONTAIN AND MINIMIZE PRODUCT SPLASHING.
- 3) PLACE CONTAINER ON STABLE, FLAT SURFACE, AS CLOSE TO KETTLE AS POSSIBLE.
- 4) STAND TO LEFT OR RIGHT SIDE OF KETTLE WHILE POURING – NOT DIRECTLY IN POUR PATH OF HOT CONTENTS.
- 5) POUR SLOWLY, MAINTAIN CONTROL OF KETTLE AT ALL TIMES, AND RETURN KETTLE BODY TO UPRIGHT POSITION AFTER CONTAINER IS FILLED OR TRANSFER IS COMPLETE.
- 6) DO NOT OVERFILL CONTAINER. AVOID DIRECT SKIN CONTACT WITH HOT CONTAINER AND ITS CONTENTS.

Before operating a cold kettle, open the petcock at the bottom of the jacket to drain any water left by condensing steam. Close the petcock before you open the steam inlet valve. Draining this water decreases the “hammering” you hear when steam enters a cold jacket.

To heat the kettle, open the steam inlet valve. Adjusting the inlet valve allows the operator to control the heating rate. Opening the valve more allows steam to flow into the jacket faster, and thereby heats the product faster.

The kettle operates efficiently with steam pressures from five PSI to the maximum working pressure for which the kettle was designed. The maximum allowable pressure is stamped on the kettle nameplate. It is 25 PSI for standard units.

Once a day, while there is still steam pressure in the jacket, bleed off any entrapped air and double check the operation of the safety valve. Pull out on its chain, or lift the lever far enough to let steam escape. Then let it snap back into place to reset the valve so that it will not leak.

Tilting the Kettle

To transfer product or empty the kettle: turn the handwheel counterclockwise. The kettle will hold its position when you stop turning the wheel. If the tilting mechanism seems to be locked, do not use force to free the kettle. Call for assistance from a Certified Service Agency, or refer to the Troubleshooting section of this manual.



Sequence of Operation

The following “action-reaction” outline is provided to help you understand how the equipment functions.

When the steam inlet valve is opened, steam flows into the jacket at a pressure determined by the boiler system, or by the pressure reducing valve which serves the kettle. In the jacket steam releases its heat to the kettle as it condenses into water. The steam trap allows condensate (water) to leave the kettle while holding the steam in.

When the steam supply is shut off, condensation of the remaining steam produces a vacuum in the jacket, but the check valve in the condensate return line keeps water from flowing back into the jacket.

Maintenance

WARNING
WHEN TESTING, AVOID ANY EXPOSURE TO THE STEAM BLOWING OUT OF THE SAFETY VALVE. DIRECT CONTACT COULD RESULT IN SEVERE BURNS.

CAUTION
USE OF ANY REPLACEMENT PARTS OTHER THAN THOSE SUPPLIED BY THE MANUFACTURER OR AN AUTHORIZED SUPPLIER WILL VOID ALL WARRANTIES AND COULD INJURE THE OPERATOR OR DAMAGE THE EQUIPMENT.



NOTICE: Contact an authorized representative when repairs are required.

Periodic Maintenance

A Service Log is provided at the back of this manual with the warranty information. Each time maintenance is performed on your kettle, enter the date on which the work was done, what was done, and who did it. Keep this manual on file and available for operators to use.

Periodic inspection will minimize equipment down time and increase the efficiency of operation. The following points should be checked:

1. Once a day, with pressure in the jacket, check the operation of the safety valve. Lift the lever of the safety valve until steam is released. Then release the lever and let the valve snap shut. If the lever does not activate, or there is no evidence of discharge, or the valve leaks, immediately discontinue use of the kettle and contact a qualified service representative.
2. At least once every 90 days, inspect fittings and valves for signs of damage or wear. Regularly examine trunnion packings and valve seats for wear, and replace them when necessary.

NOTE: Service performed by other than factory authorized personnel will void all warranties.

3. Lubricate trunnions and gears with a good grade of high temperature grease. Grease trunnions at least once every 60 days, and grease gears when inspection shows that they are dry.
4. If the kettle cover has an actuator, lubricate it every 90 days.

NOTE: Use only Calcium Complex Nr. 2 Grease.

Cleaning

WARNING

AVOID ANY DIRECT CONTACT WITH HOT SURFACES. DIRECT SKIN CONTACT COULD RESULT IN SEVERE BURNS.

CAUTION

MOST CLEANERS ARE HARMFUL TO THE SKIN, EYES, MUCOUS MEMBRANES, AND CLOTHING. PRECAUTIONS SHOULD BE TAKEN. WEAR RUBBER GLOVES, GOGGLES OR FACE SHIELD, AND PROTECTIVE CLOTHING. READ THE WARNINGS AND FOLLOW THE DIRECTIONS ON THE LABEL OF THE CLEANER CAREFULLY.

CAUTION

DO NOT MIX DIFFERENT KETTLE DRAWOFF ASSEMBLY PARTS WHEN WASHING. THEY ARE NOT INTERCHANGEABLE

NOTICE

NEVER LEAVE A CHLORINE SANITIZER IN CONTACT WITH STAINLESS STEEL SURFACES LONGER THAN 30 MINUTES. LONGER CONTACT CAN CAUSE STAINING AND CORROSION.



Scrapers or steel wool can harm the kettle surface.



Use only a sponge, cloth or plastic brush to clean the kettle.

A. Suggested Tools

1. Cleaner, such as Klenzade HC-10 or HC-32 from ECOLAB, Inc
2. Long- and short-handled kettle brushes in good condition
3. Brush suitable for cleaning the draw-off port
4. Sanitizer such as Klenzade XY-12
5. Film remover such as Klenzade LC-30

B. Procedure

1. Clean food-contact surfaces as soon as possible after use, preferably while the kettle is still hot. If the unit is in continuous use, thoroughly clean and sanitize the interior and exterior at least once every 12 hours.
2. Scrape and flush out food residues with lukewarm water. After flushing the kettle, close the draw-off valve.
3. Prepare a hot solution of the detergent/ cleaning compound as instructed by the supplier. Set some of this solution aside to use in cleaning the draw-off valve and pipe.
4. Clean the unit thoroughly, inside and outside.
5. Drain the kettle.
6. Disassemble the tangent draw-off valve. Clean the draw-off pipe and each valve part with a brush.
7. Rinse the kettle and draw-off parts thoroughly with warm water, then drain completely.
8. As part of the daily cleaning, clean all external and internal surfaces that may have been soiled. Remember to check such areas as the underside of the cover.
9. To remove burned-on materials, use a brush, sponge, cloth, plastic or rubber scraper, or plastic wool with the cleaning solution. To reduce effort required in washing, let the detergent solution sit in the kettle and soak into the residue. Do not use abrasive materials or metal tools that might scratch the surface. Scratches make the surface harder to clean and provide places for bacteria to grow.
10. Do not use steel wool, which may leave particles in the surface and cause eventual corrosion and pitting.
11. The outside of the unit may be polished with a stainless steel cleaner such as "Zepper" from Zep Manufacturing Co.

Cleaning

12. When equipment needs to be sanitized, use a solution equivalent to one that supplies 200 parts per million available chlorine. Obtain advice on sanitizing agents from your supplier of sanitizing products. Following the supplier's instructions, apply the agent after the unit has been cleaned and drained. Drain and thoroughly rinse off the sanitizer.
13. It is recommended that each piece of equipment be sanitized just before use.
14. If there is difficulty removing mineral deposits or a film left by hard water or food residues, clean the kettle thoroughly and use a deliming agent, in accordance with the manufacturer's directions. Rinse and drain the unit thoroughly before further use.
15. If cleaning problems persist, contact your cleaning product representative for assistance. The supplier has a trained technical staff with laboratory facilities to serve you.
16. If your unit is equipped with a tangent draw-off valve, disassemble it and clean the draw-off port and each valve part with a brush.

Troubleshooting

Your kettle will operate smoothly and efficiently if properly maintained. However, the following is a list of checks to make in the event of a problem. If the actions suggested do not solve the problem, call your qualified Service Representative. If an item on the list is followed by an X, the work should be done by a qualified service representative.

WARNING
TO AVOID INJURY FROM SPLASHING OR SPILLING HOT CONTENTS, EMPTY THE KETTLE THROUGH THE DRAW-OFF OR BY BAILING BEFORE ANY WORK IS DONE ON THE TILTING MECHANISM.

USE OF ANY REPLACEMENT PARTS OTHER THAN THOSE SUPPLIED BY THE MANUFACTURER AND/OR AUTHORIZED DISTRIBUTOR CAN CAUSE INJURY TO THE OPERATOR AND DAMAGE TO THE EQUIPMENT AND WILL VOID ALL WARRANTIES.

SYMPTOM	WHO	WHAT TO CHECK (* indicates work that should only be performed by a qualified service representative)
Kettle will not heat.	User	a. That the steam inlet valve is open. b. That the steam supply line is turned on. c. That the condensate return valve is open. d. That the boiler is operating properly. Steam should be supplied at a pressure greater than five PSI.
	Authorized Service Rep Only	e. Steam supply line for blockage. X f. Condensate return line for blockage. X g. Steam trap operation. X
Safety valve leaks a small amount of steam.	User	a. For contamination that prevents seating the valve. With substantial pressure in the jacket, lift the valve lever briefly all the way up, to blow the valve clean then let it snap back down to seat the valve.
	Authorized Service Rep Only	b. Safety valve for defects. Defective valve MUST be replaced with a valve rated at the same pressures. X
Safety valve leaks a large amount of steam.	Authorized Service Rep Only	a. Steam supply pressure. X b. Safety valve for defects. Defective valve MUST be replaced with a valve rated at the same pressures. X
Pipe fitting leaks.	User	a. Is the fitting tight?
	Authorized Service Rep Only	b. If tightening the packing gland does not stop the leak, replace the packing. X
Kettle is hard to tilt.	Authorized Service Rep Only	a. Tilting gear and worm for the presence of any contamination and for proper alignment and lubrication. X
Kettle makes a banging noise when steam is turned on.	User	a. Drain water from the jacket by opening the petcock at the bottom of the kettle before admitting steam into the jacket. Close the petcock before opening the steam valve.

Parts List

Key	Description	Part #
1	GEAR, WORM	012022
2	STEAM GLAND	012120
3	PACKING, 10 RING	114824
4	NUT, PACKING	012122
5	ENCLOS. TILT MECH	139043
6	GREASE FITTING, 90 DEG.	012195
7	CARRIER ASSY GEAR	137880
8	SAFETY VALVE*	-
8	3/4" SAFETY VALVE (50 PSIG)	005587
8	1/2" SAFETY VALVE (50 PSIG)	097005
9	TEE, CHROME PLATED, 3/4 NPT	012075
10	LOCKWASHER, 3/8	005618
11	SCREW CAP HEX 3/8-16X3/4	005611
12	BEARING, ROLLER	002790
13	WORM	12026
14	SHAFT	003129
15	HANDWHEEL WITH HANDLE	139152
16	HANDWHEEL SHAFT	003130
17	COLLAR	137246
18	GREASE FITTING, 45 DEG	012099
19	CASTING TRUNNION RACE	012113
20	DRAW-OFF VALVE, 2" (COMPLETE)	009046
20	DRAW-OFF VALVE, 3" (COMPLETE)	012262
-	HANDLE FOR 2" TDO VALVE	170061
-	HANDLE FOR 3" TDO VALVE	012209
-	STEM FOR 2" VALVE	009048
-	STEM FOR 3" VALVE	001908
-	WING NUT FOR 2" VALVES	009028
-	BONNET FOR 2"	009047
-	BONNET FOR 3"	003925
-	HEX NUT FOR 2"	009354
-	HEX NUT FOR 3"	003927
21	PETCOCK, JACKET DRAIN	012070
22	STAND ASSEMBLY (CALL FOR PART NUMBERS)	-

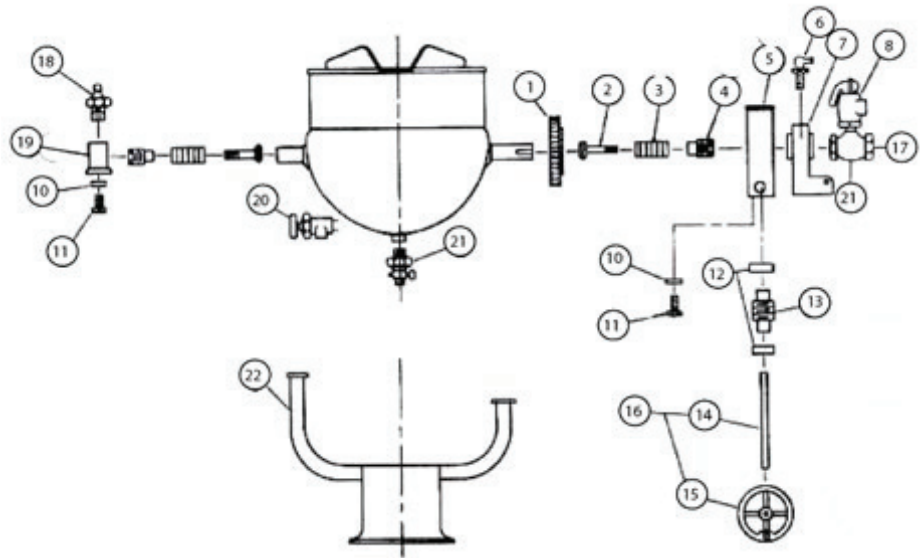

*CAUTION: Pressure and flow rate of replacement valve must be the same as originally provided.

Bucket Steam Trap

Key	Description	Qty	Part #
1	GATE VALVE	1	004180
2	90° REDUCING STREET ELBOW	1	010666
3	CLOSE NIPPLE	3	008877
4	FEMALE UNION	1	004186
5	BUCKET STEAM TRAP*	1	004183
6	SWING CHECK VALVE	1	004187
7	GLOBE VALVE	1	004222
8	CLOSE NIPPLE	2	008238
9	FEMALE UNION	1	005516
10	90° STREET ELBOW	1	008347

*NOTE: For thermostatic steam trap, use part # 010250

STEAM INLET SIZE	STEAM OUTLET SIZE	USED ON
3/4" I.P.S.	3/4 I.P.S.	ALL MODELS

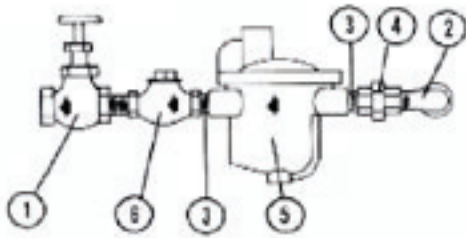

Condensate Outlet Piping

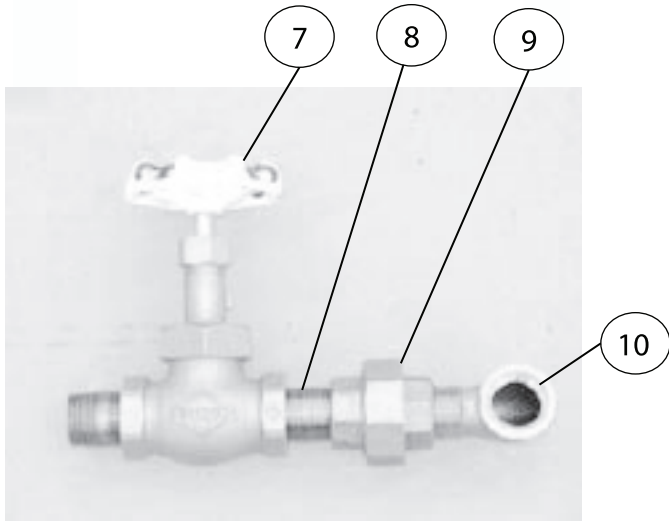

Steam Inlet Piping



BLODGETT OVEN COMPANY

www.blodgett.com

44 Lakeside Avenue, Burlington, Vermont 05401 USA
Telephone: 866-518-3977