

# **KLT-E Series**

## **ELECTRIC TRI-LEG TILTING KETTLE**

### **INSTALLATION – OPERATION – MAINTENANCE**



**BLODGETT OVEN COMPANY**

[www.blodgett.com](http://www.blodgett.com)  
44 Lakeside Avenue, Burlington, Vermont 05401 USA Telephone: (802) 658-6600 Fax: (802) 864-0183

S00051 Rev C (11/09)

## **IMPORTANT NOTES FOR INSTALLATION AND OPERATION**

It is recommended that this manual be read thoroughly and that all instructions be followed carefully.



**This is the safety alert symbol. It is used to alert you to potential personal injury hazards. Obey all safety messages that follow this symbol to avoid possible injury or death.**



**WARNING: Improper installation, operation, adjustment, alteration, service or maintenance can cause property damage, injury or death. Read the installation, operating and maintenance instructions thoroughly before installing, operating or servicing this equipment.**

**Adequate clearances must be maintained for servicing and proper operation.**

**Intended for commercial use only. Not for household use.**

**This manual should be retained for future reference.**

## TABLE OF CONTENTS

| <b>DESCRIPTION</b>                             | <b>PAGE</b> |
|--|-------------|
| Important Notes for Installation and Operation | 2           |
| 1.0 Service Connections                        | 4           |
| 2.0 Installation Instructions                  | 5           |
| 3.0 Introduction                               | 7           |
| 4.0 Operation Instructions                     | 9           |
| 5.0 Cleaning Instructions                      | 11          |
| 6.0 General Maintenance                        | 15          |
| 7.0 Troubleshooting                            | 16          |
| Appendix A, Material Safety Data Sheet         | 19          |

# 1.0 SERVICE CONNECTIONS

ELECTRICAL CONNECTION TO BE AS SPECIFIED ON DATA PLATE

## ELECTRICAL CHARACTERISTICS

| Available kW |      |        | AMPS PER LINE |       |      |      |      |      |      |      |      |
|--------------|------|--------|---------------|-------|------|------|------|------|------|------|------|
| MODEL        | STD. | OPT.   | kW            | PHASE | 208V | 220V | 240V | 380V | 415V | 480V | 600V |
| KLT-20E      | 12   | N/A    | 12            | 1     | 57.7 | 54.5 | 50.0 | N/A  | N/A  | N/A  | N/A  |
| KLT-30E      | 15   | N/A    |               | 3     | 33.3 | 31.5 | 28.9 | 18.2 | 16.7 | 14.4 | 11.6 |
| KLT-40E      | 18   | 24     | 15            | 1     | 72.1 | 68.2 | 62.5 | N/A  | N/A  | N/A  | N/A  |
| KLT-60E      | 18   | 24, 33 |               | 3     | 41.6 | 39.4 | 36.1 | 22.8 | 20.9 | 18.0 | 14.5 |
| KLT-80E      | 18   | 24, 33 | 18            | 1     | 86.5 | 81.8 | 75.0 | N/A  | N/A  | N/A  | N/A  |
| KLT-100E     | 24   | 33     |               | 3     | 50.0 | 47.2 | 43.3 | 27.3 | 25.0 | 21.7 | 21.7 |
|              |      |        | 24            | 3     | 66.6 | 63.0 | 57.7 | 36.5 | 33.4 | 28.9 | 23.1 |
|              |      |        | 33            | 3     | 91.6 | 86.6 | 79.4 | 50.1 | 45.9 | 39.7 | 31.8 |

## DIMENSIONS

| MODEL    | CAPACITY      | UNITS  | A    | B     | C     | D    | E      | F   | G      | H     | J(2") | J(3") | K(2") | K(3") | L    | M    |
|----------|---------------|--------|------|-------|-------|------|--------|-----|--------|-------|-------|-------|-------|-------|------|------|
| KLT-20E  | 20 U.S. gal.  | inches | 21   | 18    | 38    | 36   | 15     | 18  | 14     | 19.25 | 14.75 | 15.5  | 18    | 17.5  | N/A  | 63.5 |
|          | 76 litres     | mm     | 533  | 457   | 965   | 914  | 381    | 457 | 356    | 489   | 375   | 394   | 457   | 445   | N/A  | 1613 |
| KLT-30E  | 30 U.S. gal.  | inches | 24   | 20    | 38    | 39   | 16.5   | 19  | 12.375 | 19.25 | 16.75 | 17.25 | 16    | 15.5  | N/A  | 66.5 |
|          | 114 litres    | mm     | 610  | 508   | 965   | 990  | 419    | 483 | 314    | 489   | 425   | 438   | 406   | 394   | N/A  | 1689 |
| KLT-40E  | 40 U.S. gal.  | inches | 26   | 22.5  | 38    | 41   | 17.5   | 23  | 10     | 20.25 | 17.5  | 18.5  | 13.5  | 13    | N/A  | 68.5 |
|          | 152 litres    | mm     | 660  | 572   | 965   | 1041 | 445    | 584 | 254    | 514   | 445   | 470   | 343   | 330   | N/A  | 1740 |
| KLT-60E  | 60 U.S. gal.  | inches | 29.5 | 26    | 42    | 44.5 | 19.125 | 24  | 11     | 22.25 | 19.5  | 20.75 | 14    | 13.5  | 10.5 | 76   |
|          | 227 litres    | mm     | 746  | 660   | 1067  | 1130 | 486    | 610 | 280    | 565   | 495   | 527   | 356   | 343   | 267  | 1930 |
| KLT-80E  | 80 U.S. gal.  | inches | 33   | 28    | 45    | 48   | 20.875 | 27  | 12.625 | 23.75 | 20.25 | 21.25 | 15    | 14.5  | 12   | 82.5 |
|          | 303 litres    | mm     | 838  | 711   | 1143  | 1219 | 530    | 686 | 321    | 603   | 514   | 540   | 381   | 368   | 305  | 2096 |
| KLT-100E | 100 U.S. gal. | inches | 35.5 | 29.75 | 48.75 | 49.5 | 22.25  | 32  | 14.5   | 25.25 | 20.25 | 21.25 | 18.75 | 18.25 | 14   | 88.5 |
|          | 379 litres    | mm     | 902  | 755   | 1238  | 1257 | 565    | 813 | 368    | 641   | 514   | 540   | 476   | 464   | 356  | 2248 |

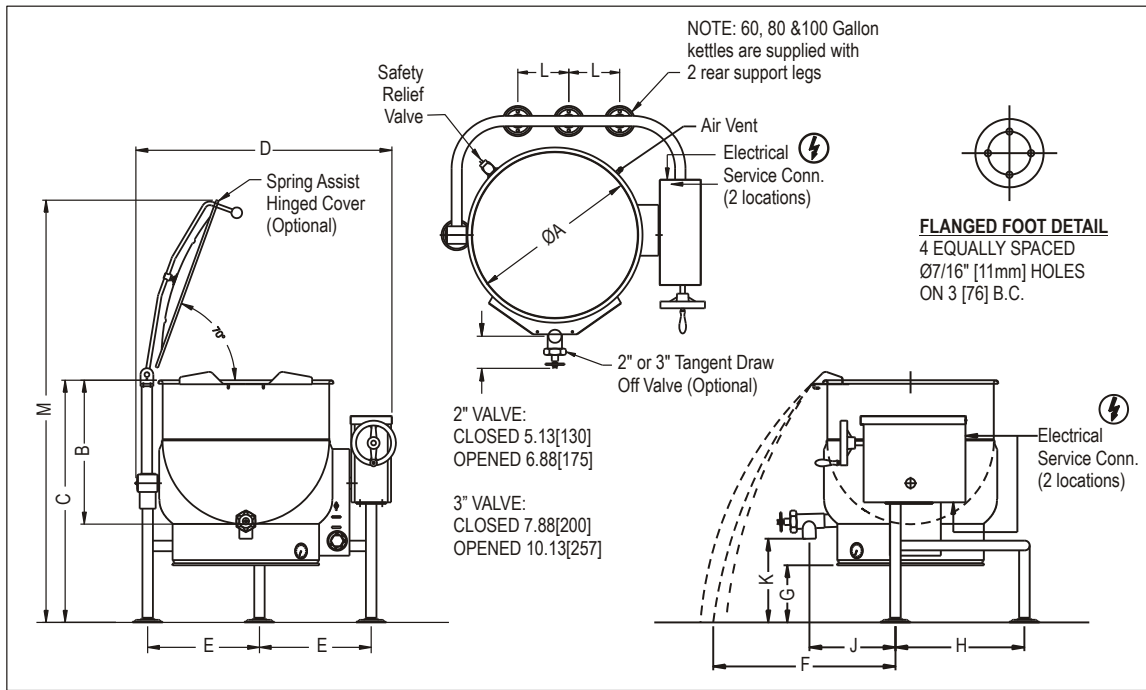

## **INSTALLATION AND SERVICE CONNECTIONS**

### **2.0 INSTALLATION INSTRUCTIONS**

#### **UNPACKING**

Immediately after unpacking, check for possible shipping damage. If the kettle is found to be damaged, save the packaging material and contact the carrier within 15 days of delivery.

Before installing, verify that the electrical service agrees with the specifications on the rating plate located on the right side of the tilt console. If the supply and equipment requirements do not agree, contact your dealer.

Select a location with drainage directly below the tangent draw-off. Allow sufficient rear clearance from wall for kettle cover to lift upright freely and completely without obstructions.

#### **INSTALLATION**

1. The kettle must be installed in accordance with:
2. State and/or local codes.
3. In the USA, the National Electrical code, ANSI/NFPA-70 (latest edition). In Canada, the Canadian Electrical Code, Part 1, CSA Standard C22.1 (latest edition).
4. Set the kettle in the installation location.
5. With the kettle in the upright position, place a carpenter's level on top of the kettle and turn the adjustable feet to level kettle side-to-side and front to back.
6. Mark hole locations on floor through anchoring holes provided in flanged adjustable feet.
7. Remove kettle and drill holes in locations marked on the floor (see installation diagram). Insert proper anchoring devices to accommodate 5/16" size lag bolts (not supplied).
8. Reposition kettle. Re-level kettle by making necessary adjustments on flanged feet.
9. Bolt down kettle and seal with Silastic or other equivalent sealing compound. Sealant must be applied not only to bolt heads but also around flanges or pedestal base making contact with floor surface to fulfill NSF requirements. Wipe off excess sealant immediately.



**WARNING: Disconnect the electrical power supply and place a tag at the disconnect switch to indicate that you are working on the circuit.**

## **ELECTRICAL CONNECTIONS**

A Control Box with power supply equivalent to electrical rating of the kettle should be located conveniently nearby.

1. Remove the wiring compartment cover and make electrical connections per wiring diagram located inside the control housing cover panel. A waterproof electrical connection from power supply to rear of control housing must be provided.
2. Kettle must be grounded in accordance with requirements of the National Electrical Code or applicable local codes.
3. Ground kettle to terminal provided in control housing.
4. Once proper connections are made, replace wiring compartment cover, turn power ON and check for proper operation.

## **SERVICE CONNECTIONS**

All internal wiring for the kettle is complete.

If faucet is provided connect water supply and check for proper operation.

## **INSTALLATION CODES AND STANDARDS**

Your electric tilting kettle must be installed in accordance with:

1. Provincial and local codes, or in the absence of local codes, with: C.S.A. C22.1 Canadian Electrical Code, Part 1, or in the U.S.A., the National Electrical Code ANSI/NFPA-70 (latest edition).
2. ANSI NFPA Standard #96, "Vapor Removal from Cooking Equipment," (latest edition), available from the National Fire Protection Association, Batterymarch Park, Quincy, MA, 02269.

### **3.0 INTRODUCTION**

#### **DESCRIPTION**

All electrically powered kettles described and referred to in this manual are pressure vessels of a double-wall construction forming a sealed jacket (chamber) enveloping the lower two thirds of the kettle bowl surface.

The kettle bowl is the container for the food product which ideally should be a liquid or semi-liquid consistency to achieve complete contact with the bowl surface. Food products will fully absorb the heat transmitted through that surface from the pressurized steam generated in the kettle jacket.

The jacket is intended to function as a self contained sealed chamber with a permanent solution of water and antifreeze sufficient not only to immerse and thereby protect replaceable electric heating elements, but also provide the steam source during the steam generating process.

The heating elements are thermostatically controlled to provide precise temperatures throughout the range from slow simmer to rolling boil.

All tilting kettles are intended to be permanently floor mounted on legs with adjustable flanged feet.

A sealed stainless steel tilt mechanism permits the kettle to tilt forward a full 90° for complete emptying. The tilting mechanism is self locking for positive stop action.

#### **CAPACITIES**

All models are suffixed with either - 20, - 30, - 40, - 60, - 80 or -100 to indicate the capacity of that kettle in US gallons. Thus an KLT-40E indicates a two thirds jacketed electrically powered steam kettle mounted on legs with a capacity of 40 US gallons.

## **FUNCTIONING MODE**

All electrically powered self steam generating kettles consist of a jacket containing a permanent solution of water and antifreeze sufficient to completely immerse and protect replaceable electric heating elements.

To minimize tampering, the Safety Valve is plumbed toward the rear of the kettle jacket. Should any component malfunction and cause the pressure in the jacket to reach the rated pressure of the kettle, this protective device will open automatically and release excessive pressurized steam.

When the Power Switch is turned ON and the Temperature Control (Thermostat) Knob dialed, the TEMPERATURE pilot light will light and contactors will close to allow power to the elements. Steam generation will commence and continue until the preselected temperature is reached, at which point the contactors open, cutting off power to heating the elements. The TEMPERATURE pilot light will then extinguish. When the temperature of the water in the jacket drops slightly, the cycle will repeat itself thus making it possible to maintain any selected precise cooking mode temperature.

The temperature required for the cooking process to function adequately must be greater than the boiling point of the liquid food product. Further, the higher the temperature, the greater the steam pressure attained in the jacket and consequently the quicker the cooking process. For example, steam pressurized at 30 p.s.i. attains a temperature of 274° Fahrenheit.

Since air is an unsuitable media through which heat may be transferred, it has been removed from the kettle jacket during testing at the factory. The Pressure Gauge should indicate vacuum in the jacket in green zone on the gauge (approximately 20 - 25 inches Hg) when the kettle is cold or has been inoperative for some time. The kettle jacket is intended to function at all times as a completely sealed self-contained chamber and it is especially advisable not to trip the safety relief valve during inoperative periods since this will break the vacuum seal and allow air to enter the kettle jacket.

The Temperature Controls (thermostats) used in these kettles have been calibrated to prevent the heating elements from generating steam pressure that would exceed the rated working pressure of the kettle. In the unlikely event that the Temperature Control fails and the heating elements remain energized, the Safety Valve will blow and release the excessive pressure and steam from the jacket, consequently lowering the water level in the jacket. The Safety Probe sensing depletion of the water level in the kettle jacket will not only activate the LOW WATER level indicator pilot light, but also signal the Liquid Level Control to switch off power and de-energize the circuit to the heating elements (preventing element burn outs) until the water level is adequately replenished.

#### 4.0 OPERATION INSTRUCTIONS



**WARNING: The kettle and its parts are hot. Use care when operating, cleaning and servicing the kettle.**

1. Ensure that the external electrical service to kettle is on.
2. Check pressure gauge for correct cold kettle reading. Reading should be in the green area of the gauge indicating 25 - 30 In. Hg (630 - 730 mm Hg) of vacuum. If reading is not low enough, follow VENTING procedure in Troubleshooting section prior to using kettle.
3. Place power switch to ON position.
4. Preheat kettle by placing thermostat knob at '10' and wait until TEMPERATURE light goes off.

**NOTE: Preheating should not be used when cooking milk and egg food products which adhere to hot cooking surfaces. These foods should be placed into kettle before heating has begun.**

5. Add food to be cooked into kettle.
6. Place thermostat knob at required temperature setting from 1 to 10 coinciding with the following table:

| THERMOSTAT SETTING | APPROXIMATE (JACKET) TEMPERATURE |              |
|--------------------|----------------------------------|--------------|
| 1                  | 140E Fahrenheit                  | 60ECelsius   |
| 2                  | 155E Fahrenheit                  | 68ECelsius   |
| 3                  | 172E Fahrenheit                  | 78E Celsius  |
| 4                  | 187E Fahrenheit                  | 86 ECelsius  |
| 5                  | 205E Fahrenheit                  | 96E Celsius  |
| 6                  | 223E Fahrenheit                  | 106E Celsius |
| 7                  | 240E Fahrenheit                  | 116E Celsius |
| 8                  | 255E Fahrenheit                  | 124E Celsius |
| 9                  | 271E Fahrenheit                  | 133E Celsius |
| 10                 | 285E Fahrenheit                  | 140E Celsius |

7. When cooking is finished set thermostat knob and power switch to OFF position.
8. Pour finished product from kettle using tilt handle. Be careful to avoid splashing.
9. Add water to kettle for cleaning purposes.
10. Wash kettle thoroughly. See CLEANING procedure, next section.

## 5.0 CLEANING INSTRUCTIONS



**CAUTION: Do not use cleaning agents that are corrosive.**



**WARNING: Disconnect the power supply to the appliance before cleaning or servicing.**



**WARNING: Never spray water into electric controls or components!**



**CAUTION: The equipment and its parts are hot. Use care when operating, cleaning and servicing.**

Your kettle should be cleaned immediately after each use or when cooking a different product. Before cleaning, check that the kettle has cooled enough to touch it.

1. Rinse the inside of the kettle thoroughly and drain to remove any food particles.
2. Using a nylon brush, clean the kettle with a mild detergent and water. Never use steel wool or scouring powder as it will scratch stainless steel. Plain steel wool can leave small pieces of steel which can rust.
3. Rinse the inside of the kettle thoroughly with clean water. Drain the kettle by tilting or using the optional tangent draw-off valve to allow the detergent and water solution to drain.
4. Wipe the exterior of the kettle with a clean, damp cloth.



**WARNING: If you are cleaning a valve that is assembled to a kettle, be sure the kettle is completely empty of any product.**

### **DRAW-OFF VALVE CLEANING**

1. If equipped with a tangent draw-off valve, turn the large hex nut on the draw-off valve counterclockwise until it is completely disengaged from the threads. Grasp the valve knob and slowly pull out the valve stem. Wash the valve stem, disk and handle. Insert a nylon brush, wet with detergent and water, into the valve body and tangent draw-off tube. Brush vigorously.
2. Replace the valve stem assembly and turn the hex nut until snug. Rinse the kettle with clean warm water.
3. Leave the draw-off valve open when the kettle is not in use.

### **DAIRY DRAW-OFF VALVE CLEANING**

1. Remove the plug by first removing the handle, then turn the plug to line up with the pin and pull with both hands. It is important to use both hands because the plug is heavy.
2. Put the plug in a plastic pail that contains a mild soap solution. A plastic pail works best, as it reduces the possibility of nicking or scratching the plug. If the plug gets scratched it may not seal correctly and could leak.
3. Use a soft cloth or soft brush and clean all surfaces.
4. Using both hands remove the valve from the soap and rinse well in another plastic pail that contains fresh water.
5. Wash out the kettle as normal.
6. Return the plug into the body. Be sure the plug is inserted into the notch and turned. Ensure the plug is tight and secure before letting go of it.

If you are cleaning a body and plug assembly, remove the plug and follow the above procedures. When finished with the plug, follow the same instructions for washing the body. Always use both hands when handling the plugs. Reassemble the plug into the body and use as normal.

### **WHAT TO DO IF SURFACE RUST APPEARS**

Metal utensils should never be used as they will scratch the surface of the equipment and rust may begin to form. To remove surface accumulation of rust from the inadvertent use of such utensils, the following procedure may be used.



**CAUTION: Improper use of this procedure may damage your appliance!**

1. Use undiluted white vinegar with a non-abrasive scouring pad (plastic) or cloth on the affected area to remove the rust stain. The appliance should not be heated and remain at room temperature during the entire cleaning process.
2. If the stain resists removal, additional exposure time with vinegar may be required, to a maximum of one hour.
3. Thoroughly wash all of the vinegar away with fresh clear water. Dry the surface completely and allow one hour before using the appliance to cook.

Following daily and period maintenance procedures will prolong the life for your equipment. Climatic conditions - salt air - may require more thorough and frequent cleaning or the life of the equipment could be adversely affected.

### **STAINLESS STEEL**

To remove normal dirt, grease or product residue from stainless steel, use ordinary soap and water (with or without detergent) applied with a sponge or cloth. Dry thoroughly with a clean cloth. Never use vinegar or any other corrosive cleaner.

To remove grease and food splatters or condensed vapours that have baked on the equipment, apply cleanser to a damp cloth or sponge and rub cleanser on the metal in the direction of the polishing lines. Rubbing cleanser as gently as possible in the direction of the polished lines will not mar the finish of the stainless steel. **NEVER RUB WITH A CIRCULAR MOTION.**

Soil and burn deposits which do not respond to the above procedure can usually be removed by rubbing the surface with **SCOTCH-BRITE™** scouring pads or **STAINLESS** scouring pads. **DO NOT USE ORDINARY STEEL WOOL** as any particles left on the surface will rust and further spoil the appearance of the finish. **NEVER USE A WIRE BRUSH, STEEL SCOURING PADS (EXCEPT STAINLESS), SCRAPER, FILE OR OTHER STEEL TOOLS.** Surfaces which are marred collect dirt more rapidly and become more difficult to clean. Marring also increases the possibility of corrosive attack. Refinishing may then be required.

**TO REMOVE HEAT TINT:** Darkened areas sometimes appear on stainless steel surfaces where the area has been subjected to excessive heat. These darkened areas are caused by thickening of the protective surface of the stainless steel and is not harmful. Heat tint can normally be removed by the foregoing, but tint which does not respond to this procedure calls for a vigorous scouring in the direction of the polish lines using **SCOTCH-BRITE™** scouring pads or a **STAINLESS** scouring pad in combination with a powdered cleanser. Heat tint action may be lessened by not applying or by reducing heat to equipment during slack periods.

All food contact surfaces must be thoroughly drained and flushed prior to cooking in the kettle.

**CONTROL PANEL:** The textured control panel should be cleaned with warm water and mild soap. Never use an abrasive cloth or steel wool. Never use cleaning solvents with a hydrocarbon base.

## 6.0 GENERAL MAINTENANCE

No general maintenance is required other than adhering to the Cleaning Procedure instructions.

**WARNING: Contact the factory, the factory representative or local service company to perform maintenance and repairs.**

## 7.0 TROUBLESHOOTING

### 7.1 LOW WATER LEVEL

Proper water level must be maintained within the jacket for the kettle to operate. Depletion of water may occur from excessive opening of or leakage through the safety relief valve.

If water is below required operating level, either initially at start-up or during use, the kettle will automatically shut off and the LOW WATER signal light will come on.

In order for the kettle to operate, the following procedure must be followed:

The kettle must be cool before proceeding with the following steps.

1. Trip the safety relief valve lever to relieve all pressure from the kettle jacket.
2. At exterior rear of kettle jacket remove nut from Air Vent.
3. Insert funnel into Air Vent opening and slowly add the indicated amount of clean water for:

| <b>CAPACITY</b>   | <b>ADD:</b> |              | <b>IF COMPLETELY EMPTY, ADD:</b> |              |
|-------------------|-------------|--------------|----------------------------------|--------------|
| 20 gallon kettle  | 140 ounces  | 4.14 litres  | 376 ounces                       | 11.12 litres |
| 30 gallon kettle  | 150 ounces  | 4.44 litres  | 504 ounces                       | 14.90 litres |
| 40 gallon kettle  | 220 ounces  | 6.50 litres  | 548 ounces                       | 16.20 litres |
| 60 gallon kettle  | 250 ounces  | 7.39 litres  | 586 ounces                       | 17.33 litres |
| 80 gallon kettle  | 340 ounces  | 10.05 litres | 850 ounces                       | 25.12 litres |
| 100 gallon kettle | 420 ounces  | 12.42 litres | 1088 ounces                      | 32.17 litres |

4. Replace air vent nut.
5. Follow AIR VENTING INSTRUCTIONS below.
6. Continue normal operating procedure of kettle.

## **7.0 TROUBLESHOOTING (Continued)**

### **7.2 EXTREMELY SLOW COOKING TIME**

1. If the cooking time is abnormally slow, then the difficulty may be due to air being present in the kettle jacket. To remove air, follow AIR VENTING INSTRUCTIONS.
2. If the kettle will not reach and maintain Pressure Gauge zone in the green area on the gauge when cold, a slow leak may have developed in the jacket. Check all fitting connections to jacket including the heating element gasket. Tighten or replace if necessary.
3. Slow cooking time may also be due to a burnt out heating element. Test elements and if defective, replace complete element assembly.

### **7.3 KETTLE WILL NOT OPERATE WHEN TURNED ON**

1. Check that power supply is available to kettle.
2. Kettle will not operate if water level is inadequate in jacket. Follow LOW WATER LEVEL instructions.
3. If water level is sufficient and kettle refuses to operate, then check that Tilt Interlock Switch in Console is fully engaged when kettle is in its normally upright position. Adjust Retaining Tilt Collar if necessary to assure complete contact with switch and if kettle still does not operate, then check for defective switch and/or loose wiring connections.
4. When Thermostat Knob is dialed and TEMPERATURE indicator light does not come on, then it may be due to either a defective Thermostat or loose wiring connection(s).
5. Check that the Contactor(s) are being energized and power is being made available to the heating elements when thermostat is dialed. Replace defective Contactor(s).

### **7.4 DRAW-OFF VALVE LEAKS**

If leak occurs through the valve stem, replace the "O" ring. If the leak is caused by faulty sealing between the stem disc and valve seat, this can be corrected by cleaning off dried on food residue with an extremely fine emery cloth. If the vulcanized rubber stem piece has been damaged, it must be replaced.

**NOTICE: Draw-Off Valve has a vulcanized rubber coated stem for better sealing. Do not over-tighten. This may cause the rubber to pull away from stem and permanently damage it. This is not covered under warranty.**

## 7.5 AIR VENTING INSTRUCTIONS

Check vacuum/pressure gauge when the kettle is cold. Gauge should be in the green vacuum zone, indicating a vacuum between 25-30 In. Hg (630 - 730 mm Hg). If not, air must be vented (removed) for proper heating. Use the following procedures to vent air.

1. Place power switch ON with kettle empty.
2. Set temperature control thermostat to '10'. Heat kettle until indicator light goes off.
3. Using a 7/16" wrench, open bleed vent one full turn for 10 seconds and then close. (Located on back of kettle, before pressure relief valve.)



**WARNING: SCALD HAZARD. Live steam will escape the bleed nut when opened. Stay clear of live steam when performing this operation.**

4. Cool kettle. Check for proper vacuum in green area of gauge. If vacuum was not established, repeat steps 1 - 4.

**APPENDIX 'A'**

**MATERIAL SAFETY DATA SHEET**

**PREPARATION INFORMATION:**

Prepared for use in Canada by: E H & S Product Regulatory Management Department  
DOW CHEMICAL CANADA INC.  
P.O. Box 1012  
Sarnia, Ontario, N7T 7K7

(800) 331-6451

**1. CHEMICAL PRODUCT AND COMPANY IDENTIFICATION**

**IN CASE OF EMERGENCY:** Fort Saskatchewan, Alberta: (780) 998-8282  
Sarnia, Ontario: (519) 339-3711  
Varenes, Quebec: (450) 652-1000

**Product::** **DOWFROST\* HD HEAT TRANSFER FLUID, DYED**

Product Code: 04632

Effective Date: 2/20/01 Date Printed: 07/10/02 MSD: 002239

DOW CHEMICAL CANADA INC.  
P.O. Box 1012  
Sarnia, Ontario, N7T 7K7

Prepared for use in Canada by the E H & S Product Regulatory Management Department; Phone: (800) 331-6451.

**1. COMPOSITION/INFORMATION ON INGREDIENTS**

|                       |                  |     |     |
|-----------------------|------------------|-----|-----|
| Propylene Glycol      | CAS# 000057-55-6 |     | 94% |
| Dipotassium Phosphate | CAS# 007758-11-4 | <5% |     |
| Deionized Water       | CAS# 007732-18-5 |     | <5% |

*\* or (R) indicates a trademark of The Dow Chemical Company.*

## **MATERIAL SAFETY DATA SHEET**

**Product: DOWFROST\* HD HEAT TRANSFER FLUID, DYED**

**Product Code: 04632**

**Effective Date: 02/20/01, Date Printed: 07/10/02, MSD: 002239**

### **2. HAZARDS IDENTIFICATION**

#### **EMERGENCY OVERVIEW**

|  |
|--|
| Clear yellow liquid. Odourless. Avoid temperatures above 450EF, 232EC. |
|--|

**POTENTIAL HEALTH EFFECTS** (See Section 11 for toxicological data.)

**EYE:** May cause slight transient (temporary) eye irritation. Corneal injury is unlikely. Mists may cause eye irritation.

**SKIN CONTACT:** Prolonged contact is essentially nonirritating to skin. A single prolonged exposure is not likely to result in the material being absorbed through skin in harmful amounts. Repeated exposures may cause flaking and softening of skin.

**INGESTION:** Single dose oral toxicity is considered to be extremely low. No hazards anticipated from swallowing small amounts incidental to normal handling operations.

**INHALATION:** At room temperature, vapours are minimal due to physical properties. Mists may cause irritation of upper respiratory tract (nose and throat).

**SYSTEMIC (OTHER TARGET ORGAN) EFFECTS:** Repeated excessive exposure to propylene glycol may cause central nervous system effects.

**CANCER INFORMATION:** Did not cause cancer in laboratory animals.

**TERATOLOGY (BIRTH DEFECTS):** Birth defects are unlikely. Exposures having no adverse effects on the mother should have no effect on the fetus.

**REPRODUCTIVE EFFECTS:** In animal studies, has been shown not to interfere with reproduction.

*\* or (R) indicates a trademark of The Dow Chemical Company.*

## **MATERIAL SAFETY DATA SHEET**

**Product: DOWFROST\* HD HEAT TRANSFER FLUID, DYED**

**Product Code: 04632**

**Effective Date: 02/20/01, Date Printed: 07/10/02, MSD: 002239**

### **4. FIRST AID**

EYES: Flush eyes with plenty of water.

SKIN: Wash off in flowing water or shower.

INGESTION: No adverse effects anticipated by this route of exposure incidental to proper industrial handling.

INHALATION: Remove to fresh air if effects occur. Consult a physician.

NOTE TO PHYSICIAN: No specific antidote. Supportive care. Treatment based on judgment of the physician in response to reactions of the patient.

### **5. FIRE FIGHTING MEASURES**

#### **FLAMMABLE PROPERTIES**

FLASH POINT: 214EF, 107EC (based on a similar material)

METHOD USED: PMCC

AUTOIGNITION TEMPERATURE: NOT DETERMINED

#### **FLAMMABILITY LIMITS**

LFL: Not determined

UFL: Not determined

*\* or (R) indicates a trademark of The Dow Chemical Company.*

## **MATERIAL SAFETY DATA SHEET**

**Product: DOWFROST\* HD HEAT TRANSFER FLUID, DYED**

**Product Code: 04632**

**Effective Date: 02/20/01, Date Printed: 07/10/02, MSD: 002239**

**HAZARDOUS COMBUSTION PRODUCTS:** During a fire, smoke may contain the original material in addition to unidentified toxic and/or irritating compounds. Hazardous combustion products may include and are not limited to carbon monoxide and carbon dioxide.

**OTHER FLAMMABILITY INFORMATION:** Violent steam generation or eruption may occur upon application of direct water stream to hot liquids. Flammable concentrations of vapour can accumulate at temperatures above 214°F. Liquid mist of this product can burn. Spills of these organic liquids on hot fibrous insulations may lead to lowering of the autoignition temperatures possibly resulting in spontaneous combustion. Container may rupture from gas generation in a fire situation.

**EXTINGUISHING MEDIA:** Water fog or fine spray, carbon dioxide, dry chemical, foam. Alcohol resistant foams (ATC type) are preferred if available. General purpose synthetic foams (including AFFF) or protein foams may function, but much less effectively. Do not use direct water stream. May spread fire.

**MEDIA TO BE AVOIDED:** Do not use direct water stream.

**FIRE FIGHTING INSTRUCTIONS:** Keep people away. Isolate fire area and deny unnecessary entry. Burning liquids may be moved by flushing with water to protect personnel and minimize property damage. Burning liquids may be extinguished by dilution with water. Do not use direct water stream. May spread fire. Fight fire from protected location or safe distance. Consider use of unmanned hose holder or monitor nozzles. Use water spray to cool fire exposed containers and fire affected zone until fire is out and danger of re-ignition has passed. Immediately withdraw all personnel from area in case of rising sound from venting safety device or discolouration of the container. Move container from fire area if this is possible without hazard.

**PROTECTIVE EQUIPMENT FOR FIRE FIGHTERS:** Wear positive-pressure self-contained breathing apparatus (SCBA) and protective fire fighting clothing (includes fire fighting helmet, coat, pants, boots and gloves). If protective equipment is not available or not used, fight fire from a protected location or safe distance.

*\* or (R) indicates a trademark of The Dow Chemical Company.*

## **MATERIAL SAFETY DATA SHEET**

**Product: DOWFROST\* HD HEAT TRANSFER FLUID, DYED**

**Product Code: 04632**

**Effective Date: 02/20/01, Date Printed: 07/10/02, MSD: 002239**

### **6. ACCIDENTAL RELEASE MEASURES** (See Section 15 for Regulatory Information)

PROTECT PEOPLE: Use appropriate safety equipment. For additional information, refer to Section 8, Exposure Controls/ Personal Protection.

PROTECT THE ENVIRONMENT: Avoid contamination of all waterways.

CLEAN-UP: See Section 13, Disposal Consideration.

### **1. HANDLING AND STORAGE**

SPECIAL PRECAUTIONS TO BE TAKEN IN HANDLING AND STORAGE: No special handling requirements data available.

HANDLING: See Section 8, Exposure Controls/Personal Protection.

STORAGE: See Section 10, Stability and Reactivity.

### **2. EXPOSURE CONTROLS/PERSONAL PROTECTION**

ENGINEERING CONTROLS: Provide general and/or local exhaust ventilation to control airborne levels below the exposure guidelines.

#### PERSONAL PROTECTIVE EQUIPMENT

EYE/FACE PROTECTION: Use safety glasses. Safety glasses should be sufficient for most operations; however, for misty operations wear chemical goggles.

SKIN PROTECTION: Use gloves impervious to this material.

RESPIRATORY PROTECTION: Atmospheric levels should be maintained below the exposure guideline. When respiratory protection is required for certain operations, use an approved air-purifying respirator. In misty atmospheres, use an approved mist respirator.

*\* or (R) indicates a trademark of The Dow Chemical Company.*

## **MATERIAL SAFETY DATA SHEET**

**Product: DOWFROST\* HD HEAT TRANSFER FLUID, DYED**

**Product Code: 04632**

**Effective Date: 02/20/01, Date Printed: 07/10/02, MSD: 002239**

EXPOSURE GUIDELINES: Propylene glycol: AIHA WEEL is 50 ppm total, 10 mg/m<sup>3</sup> aerosol only.

### **9. PHYSICAL AND CHEMICAL PROPERTIES**

|                                  |                      |
|----------------------------------|----------------------|
| APPEARANCE/PHYSICAL STATE:       | Clear yellow liquid. |
| ODOUR:                           | Odourless            |
| VAPOUR PRESSURE:                 | 0.22 mmHg @ 20EC     |
| VAPOUR DENSITY:                  | 2.6                  |
| BOILING POINT:                   | 320EF, 160EC         |
| SOLUBILITY IN WATER/MISCIBILITY: | Complete             |
| SPECIFIC GRAVITY OR DENSITY:     | 1.058 @ 25/25EC      |

### **10. STABILITY AND REACTIVITY**

CHEMICAL STABILITY: Thermally stable at typical use temperatures.

CONDITIONS TO AVOID: Avoid use temperatures above 450EF, 232EC. Product can degrade at elevated temperatures. Generation of gas during decomposition can cause pressure in closed systems.

INCOMPATIBILITY WITH OTHER MATERIALS: Avoid contact with oxidizing materials. Avoid contact with strong acids

HAZARDOUS DECOMPOSITION PRODUCTS: Hazardous decomposition products depend upon temperature, air supply and the presence of other materials.

HAZARDOUS POLYMERIZATION: Will not occur.

**11. TOXICOLOGICAL INFORMATION** (See Section 3 for Potential Health Effects. For detailed toxicological data, write or call the address or non-emergency number shown in Section 1).

SKIN: The LD50 for skin absorption in rabbits is >10,000 mg/kg.

*\* or (R) indicates a trademark of The Dow Chemical Company.*

## **MATERIAL SAFETY DATA SHEET**

**Product: DOWFROST\* HD HEAT TRANSFER FLUID, DYED**

**Product Code: 04632**

**Effective Date: 02/20/01, Date Printed: 07/10/02, MSD: 002239**

SKIN: The LD50 for skin absorption in rabbits is >10,000 mg/kg.

INGESTION: The oral LD50 for rats is 20,000 - 34,000 mg/kg.

MUTAGENICITY: In vitro mutagenicity studies were negative. Animal mutagenicity studies were negative.

**12. ECOLOGICAL INFORMATION** (For detailed Ecological data, write or call the address or non-emergency number shown in Section 1.)

### ENVIRONMENTAL FATE

**MOVEMENT & PARTITIONING:** Based largely or completely on data for major component(s). Bioconcentration potential is low (BCF less than 100 or Log Pow less than 3). Potential for mobility in soil is very high (Koc between 0 and 50).

**DEGRADATION AND PERSISTENCE:** Based largely or completely on data for major component(s). Material is readily biodegradable. Passes OECD test(s) for ready biodegradability. Degradation is expected in the atmospheric environment within minutes to hours.

**ECOTOXICITY:** Based largely or completely on data for major component(s). Material is practically non-toxic to aquatic organisms on an acute basis (LC50/EC50 >100 mg/L in most sensitive species).

**13. DISPOSAL CONSIDERATIONS** (See Section 15 for Regulatory Information)

**DISPOSAL: DO NOT DUMP INTO ANY SEWERS, ON THE GROUND OR INTO ANY BODY OF WATER.** All disposal methods must be in compliance with all Federal, State/Provincial and local laws and regulations. Regulations may vary in different locations. Waste characterizations and compliance with applicable laws are the responsibility solely of the waste generator. **THE DOW CHEMICAL COMPANY HAS NO CONTROL OVER THE MANAGEMENT PRACTICES OR MANUFACTURING PROCESSES OF PARTIES HANDLING OR USING THIS MATERIAL. THE INFORMATION PRESENTED HERE PERTAINS ONLY TO THE PRODUCT AS SHIPPED IN ITS INTENDED CONDITION AS DESCRIBED IN MSDS SECTION 2 (Composition/Information On Ingredients).**

*\* or (R) indicates a trademark of The Dow Chemical Company.*

## **MATERIAL SAFETY DATA SHEET**

**Product: DOWFROST\* HD HEAT TRANSFER FLUID, DYED**

**Product Code: 04632**

**Effective Date: 02/20/01, Date Printed: 07/10/02, MSD: 002239**

FOR UNUSED & UNCONTAMINATED PRODUCT, the preferred options include sending to a licensed, permitted: recycler, reclaimer, incinerator or other thermal destruction device.

As a service to its customers, Dow can provide names of information resources to help identify waste management companies and other facilities which recycle, reprocess or manage chemicals or plastics, and that manage used drums. Telephone Dow's Customer Information Center at 800-258-2436 or 989-832-1556 for further details.

### **14. TRANSPORT INFORMATION**

**DEPARTMENT OF TRANSPORTATION (D.O.T.):** For D.O.T. regulatory information, if required, consult transportation regulations, product shipping papers, or contact your Dow representative.

**CANADIAN TDG INFORMATION:** For TDG regulatory information, if required, consult transportation regulations, product shipping papers, or your Dow representative.

### **15. REGULATORY INFORMATION** (Not meant to be all-inclusive – selected regulations represented).

**NOTICE:** The information herein is presented in good faith and believed to be accurate as of the effective date shown above. However, no warranty, express or implied is given. Regulatory requirements are subject to change and may differ from one location to another; it is the buyer's responsibility to ensure that its activities comply with federal, state or provincial, and local laws. The following specific information is made for the purpose of complying with numerous federal, state or provincial, and local laws and regulations. See other sections for health and safety information.

*\* or (R) indicates a trademark of The Dow Chemical Company.*

## MATERIAL SAFETY DATA SHEET

Product: DOWFROST\* HD HEAT TRANSFER FLUID, DYED

Product Code: 04632

Effective Date: 02/20/01, Date Printed: 07/10/02, MSD: 002239

### U.S. REGULATIONS

SARA 313 INFORMATION: To the best of our knowledge, this product contains no chemical subject to SARA Title III Section 313 supplier notification requirements.

SARA HAZARD CATEGORY: This product has been reviewed according to the EPA "Hazard Categories" promulgated under Sections 311 and 312 of the Superfund Amendment and Reauthorization Act of 1986 (SARA Title III) and is considered, under applicable definitions, to meet the following categories:

Not to have met any hazard category.

TOXIC SUBSTANCES CONTROL ACT (TSCA):

All ingredients are on the TSCA inventory or are not required to be listed on the TSCA inventory.

STATE RIGHT-TO-KNOW: The following product components are cited on certain state lists as mentioned. Non-listed components may be shown in the composition section of the MSDS.

| <u>CHEMICAL NAME</u> | <u>CAS NUMBER</u> | <u>LIST</u> |
|----------------------|-------------------|-------------|
| 1, 2-Propanediol     | 000057-55-6       | PA1         |

PA1= Pennsylvania Hazardous Substance (present at greater than or equal to 1.0%).

OSHA HAZARD COMMUNICATION STANDARD:

This product is not a "Hazardous Chemical" as defined by the OSHA Hazard Communication Standard, 29 CFR 1910.1200.

*\* or (R) indicates a trademark of The Dow Chemical Company.*

## **MATERIAL SAFETY DATA SHEET**

**Product: DOWFROST\* HD HEAT TRANSFER FLUID, DYED**

**Product Code: 04632**

**Effective Date: 02/20/01, Date Printed: 07/10/02, MSD: 002239**

### **CANADIAN REGULATIONS**

WHMIS INFORMATION: The Canadian Workplace Hazardous Materials Information System (WHMIS) Classification for this product is:

This product is not a "Controlled Product" under WHMIS.

CANADIAN ENVIRONMENTAL PROTECTION ACT (CEPA)

This product contains one or more substances which are not listed on the Canadian Domestic Substances List (DSL). Contact your Dow representative for more information.

### **16. OTHER INFORMATION**

MSDS STATUS: Revised to 16 section format.

*\* or (R) indicates a trademark of The Dow Chemical Company.*

*The information herein is given in good faith, but no warranty, express or implied, is made. Consult The Dow Chemical Company for further information.*