

## BC-20G Combination-Oven/Steamer



Shown with optional MenuSelect control

Project \_\_\_\_\_

Item No. \_\_\_\_\_

Quantity \_\_\_\_\_

All data is shown per oven section, unless otherwise indicated.

Refer to operator manual specification chart for listed model name.

### EXTERIOR CONSTRUCTION

- Stainless steel top, front, sides and back
- Stainless steel door, right hand hinge only
- Tempered viewing windows
- Condensate drip pan on oven transport cart

### INTERIOR CONSTRUCTION

- Fully welded stainless steel frame
- Fully insulated cooking chamber
- Fixed drain bottom center of cavity
- Easily replaceable oven mounted door gasket

### OPERATION

- Standard control with four function selection switch for steam, hot air, combined steam/hot air, cool down, Vario Steam® and steam on demand feature
- Solid state rotary dial thermostat - range 150-500°F (66-260°C)
- Motor driven 120 minute timer shuts down at elapsed time
- Two speed fan
- Magnetic door interlock switch shuts off oven when door is opened
- Electronic Ignition
- Automatic temperature control
- Open vented system. Condenses steam and drains away by-products of the cooking process, eliminates flavor transfer
- Automatic steam regulation
- Self-contained, self-flushing steam generator separate from cooking compartment for instant steam recovery when switching modes
- Delimiting light flashes when steam generator requires delimiting

### CAPACITY

- TC14 - 28 steam table pans or 14 bake pans
- TC20 - 20 steam table pans or 20 bake pans
- TC10 Prison Cart - 20 steam table pans or 10 bake pans

### STANDARD FEATURES

- Ten (10) stainless steel wire shelves
- Internal Semi-Automatic Delimiting pump with delivery hose and delimiting container
- Pressure spray bottle
- Hose and spray assembly for interior cleaning
- TC14 transport cart (14 shelf positions)
- Factory installed water pressure regulator and vented drain assembly (2 per section)
- Start-up inspection service by factory authorized service agent - operational testing and installation inspection
- One year parts and labor oven warranty\*

\* For all international markets, contact your local distributor.

### OPTIONS AND ACCESSORIES

(AT ADDITIONAL CHARGE)

- **Additional transport cart (shelves not included)**
  - TC10 - 10 shelf position
  - TC14 - 14 shelf position
  - TC20 - 20 shelf position
  - 96 plate banquet cart
- MenuSelect control can hold multi-stage programming for up to 99 products, includes Cook & Hold, core probe cooking and USB port
- Locking control panel
- Locking door hasp
- Tamper proof screws
- Solid door (no glass)
- Additional stainless steel wire shelves
- Core temperature probe with digital readout
- 6-1/2" (165.1mm) seismic legs
- Chicken roasting rack
- Extended warranty

### OPTIONS AND ACCESSORIES

(AT NO CHARGE)

- 208/240 volt
- LP gas



**BLODGETT COMBI**

[www.blodgett.com](http://www.blodgett.com)

44 Lakeside Avenue, Burlington, VT 05401  
Phone: (802) 658-6600 • Fax: (802) 864-0183

## BC-20G

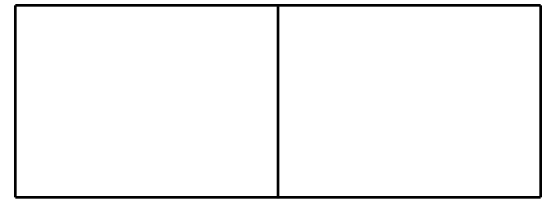

APPROVAL/STAMP

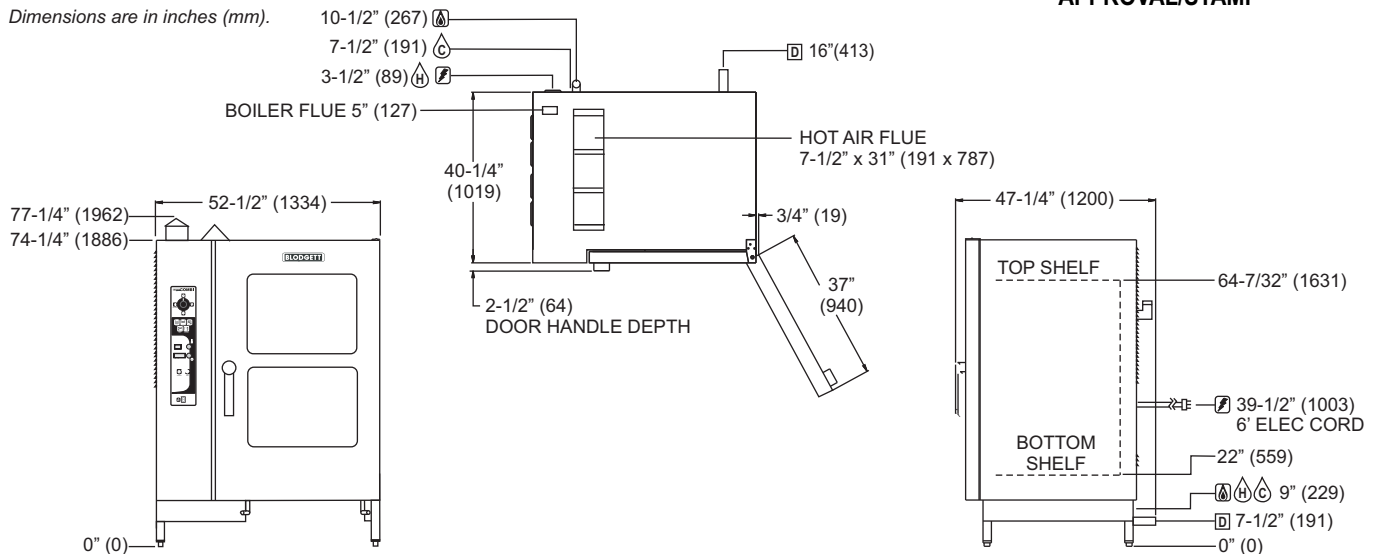

### SHORT FORM SPECIFICATIONS

Provide Blodgett Combi model BC-20G single or double, gas combination-oven/steamer. Unit shall have the ability to cook with pressureless steam, hot air, or combination of steam and hot air. Mechanical mode switch shall allow the operator to choose four modes, steam, hot air, combi or cool down mode. Timer to be 120 minute motor driven. Temperature control to be solid state with rotary knob. Unit shall utilize a roll-in cart capable of being used in conjunction with a blast chiller or warming unit. Unit shall include two speed fan, steam on demand feature, deliming indicator light and Vario Steam® feature. The interior shall have the capability of being hosed down for cleaning. Door gaskets shall be easily removable for replacement and cleaning. Unit shall be open vented for waist air quenching. Steam generator shall be separate from the cooking compartment in order to provide the fastest possible steam recovery. Steam generator shall flush automatically to cut down on mineral build up. Unit shall include Deliming container with semi-automatic pump for storing and dispensing deliming solution. A start-up inspection service will be performed by our factory authorized agent at no cost to the operator.

### DIMENSIONS:

**Floor space:** 47-1/4" D x 52-1/2" W (1200.2 x 1333.5mm)  
**Height:** 77-1/4" (162.2mm)

### OVEN CLEARANCES:

Right Side 6" (152.4mm)  
 Rear 6" (152.4mm)  
 Left Side 6" (152.4mm)

### MINIMUM ENTRY CLEARANCE:

Uncrated 47-1/4" (1200.2mm)  
 Crated 49-1/4" (1251mm)

### SHIPPING INFORMATION:

**Approx. Weight:**  
 BC-20G 1400 lbs. (635 kg)  
 Transport Cart 135 lbs. (61 kg)  
**Crate sizes:**  
 61" (1549.4mm) x 49" (1244.6mm) x 79" (2006.6mm)

### POWER SUPPLY:

Standard 115VAC 15 amp Nema 5-15 receptacle  
 Option 208/240VAC 20 amp Nema 6-20 receptacle  
 Export Export voltages available on request  
 Blodgett recommends a Pass & Seymour, model 2095, GFCI for this oven model due to the use of a variable frequency drive.

### GAS SUPPLY:

1" NPT  
**Inlet Pressure:**  
 Natural 7.0" W.C. static to unit  
 Propane 11.0" W.C. static to unit  
**Maximum Input:**  
 Hot Air 125,000 BTU/hr  
 Boiler 90,000 BTU/hr  
 Total 215,000 BTU/hr

### WATER SUPPLY & DRAIN:

**Water Supply:** Good quality water feed is the responsibility of the owner. Water quality must be within the following general guidelines.

**TDS:** < 100 ppm      **Hardness:** 80-120 ppm      **pH:** 7.0 - 8.0  
**Chlorides:** < 30 ppm      **Pressure:** 40(min)-50(max) PSI      **Chlorine:** 0 ppm  
 3/4" hose cold water connection (hot or filtered water optional)

The best defense against poor water quality is a water filter system designed to meet your water quality conditions. Blodgett offers an optional water filter from Terry Corp. for this unit. For further advice and support, contact Terry at 800-557-3449.

### Drain:

2" drain connection 122°F (50°C) avg. drain temp.  
 Appliance is to be installed with backflow protection in accordance with Federal, State or Local codes.

**NOTE:** The company reserves the right to make substitutions of components without prior notice

**BLODGETT COMBI**

[www.blodgett.com](http://www.blodgett.com)

44 Lakeside Avenue, Burlington, VT 05401 • Phone: (802) 658-6600 • Fax: (802) 864-0183