

BCX-14G
Single or Double Gas
Combination-Oven/Steamer

Shown with optional stand and casters

OPTIONS AND ACCESSORIES

(AT ADDITIONAL CHARGE)

- **Legs, stands and casters**
 - 4" (101.6mm) adjustable legs for double stack
 - 6" (152.4mm) adjustable legs
 - 6" (152.4mm) seismic legs
 - 25" (635mm) adjustable legs
 - Floor stand with rack supports
 - Stand mount casters
- MenuSelect control can hold multi-stage programming for up to 99 products, includes Cook & Hold and core probe cooking
- Additional 6-1/2" core temperature probe
- Additional stainless steel wire shelves
- Chicken roasting rack
- Single source water manifold
- Water pressure regulator (1 per section)
- Extended warranty

OPTIONS AND ACCESSORIES

(AT NO CHARGE)

- LP gas
- 208/240 volt

Project _____

Item No. _____

Quantity _____

All data is shown per oven section, unless otherwise indicated.
Refer to operator manual specification chart for listed model names.

EXTERIOR CONSTRUCTION

- Stainless steel top, front and sides
- Dual pane tempered viewing window with hinged inner glass for easy cleaning
- Door mounted condensate trough
- Top and bottom mount, easily adjustable door hinges
- Pivot out user interface panel for service access

INTERIOR CONSTRUCTION

- Fully welded stainless steel frame
- Fully insulated cooking chamber
- Fixed drain bottom center of cavity
- Easily removable stainless steel side rails
- Coved corner liner for ease of cleaning

OPERATION

- Standard control with function selection for steam, combi, hot air and cool down
- Retherm band on control
- Steam on demand feature
- Thermostat control to 500F
- Multiple speed reversing fan for even bake
- Dual stage door latch to vent steam before fully opening door
- Cavity vent control provides ability to release steam at the turn of a switch
- Integral door switch
- Electronic spark ignition
- Open vented system. Condenses steam and drains away by-products of the cooking process, eliminates flavor transfer
- Self contained, self-flushing steam generator separate from cooking compartment for instant steam recovery when switching modes
- Control prompts user to delime when steam generator requires deliming

CAPACITY

- Fourteen 12" x 20" x 2-1/2" deep pans at 3-1/4" spacing
- Seven 18" x 26" deep pans at 3-1/4" spacing

STANDARD FEATURES

- Five (5) stainless steel wire shelves per section (capacity for 7)
- Hinged pressure panel for cleanability
- Four halogen lights for superior cavity illumination
- Retractable hose reel hidden behind door, no extraneous hoses
- Stacking kit and casters for double stack ovens
- Semi-auto delime system
- Deliming bottle and pump assembly
- Pressure spray bottle for oven cleaning
- 6-1/2" core temperature probe
- Start-up inspection service by factory authorized service agent
- One year parts and labor oven warranty*

* For all international markets, contact your local distributor.

**BLODGETT COMBI**

www.blodgett.com

44 Lakeside Avenue, Burlington, VT 05401

Toll Free: (800) 331-5842 • Phone: (802) 860-3700 • Fax: (802) 864-0183

BCX-14G

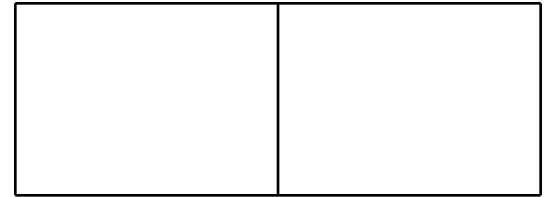

DIMENSIONS ARE IN INCHES (MM)

All height dimensions are given for the unit only.

See below for heights of the legs, casters and stands.

Unfiltered Water - Condensate, cold only
 Filtered Water - Boiler, hot or cold

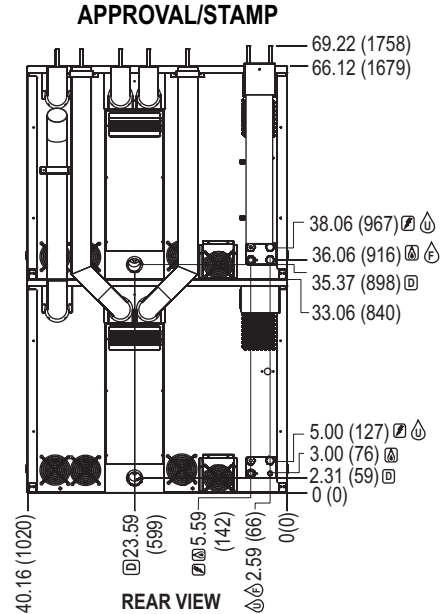
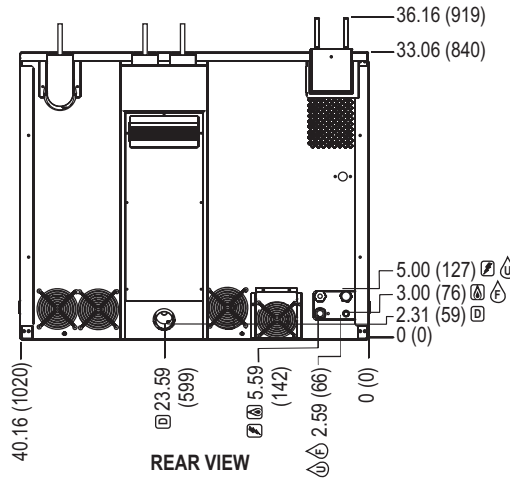
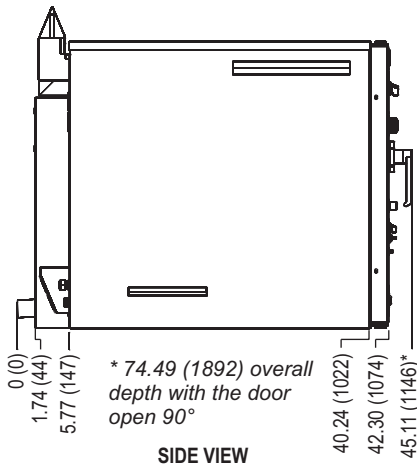

SHORT FORM SPECIFICATIONS: Provide Blodgett Combi model BCX-14G single, gas combination-oven/steamer. Unit shall have the ability to cook with pressureless steam (212F), hot air, or combination of steam and hot air (with an operating range 140F to 500F), vario-steaming (operating range 140F to 212F), low temperature cooking and holding, rethermalizing, cool down mode and our Exclusive Steam on Demand steam injection system. Oven capacity to accept 7ea 18x26 bake pans or 14ea 12x20x2.5" full size steam table pans with 3-1/4" spacing. Front access service user interface control panel and service diagnosis system. Unit shall be constructed with a fully welded stainless steel frame. Cooking chamber shall be constructed with 304 series with bright-annealed stainless steel finish and coved corners. Integrated retractable wash down hose to include front water shut off valve. Oven cavity shall be open to the atmosphere with a thermostatically controlled quench box with a flow rate of less than 8 gallons per hour (total water consumption not to exceed 15 gallons per hour). Unit shall include a four speed, bi-directional fan with vent switch to control humidity in the cooking chamber. Dual pane thermal glass window with 180 degree door swing, two-step safety door-latch with adjustable door hinges, door mounted drip pan. Unit to include a detachable 6-1/2" core temperature probe and four halogen lights. Supply with exclusive time to delime indicator with adjustable settings of 30, 60 or 90 hours of run time, semi-automatic deliming system. Where applicable, quantities in this spec are doubled for stacked units. A start-up inspection service will be performed by our factory-authorized agent at no cost to the operator. One-year parts and labor warranty, standard.

DIMENSIONS:

Floor space: 42.30" x 40.19" (1074 x 1021mm)

Unit Height:

Single 36.16" (919mm)

Double 69.22" (1758mm) without casters/legs

Additional Height:

Low profile caster for stacked units 4" (101.6mm)

4" adjustable legs for stacked units 4.88" - 6" (123.8-152.4mm)

6" adjustable legs 6.88" - 8" (174.6-203.2mm)

6" adjustable seismic legs 6.63" - 8" (168.3-203.2mm)

25" adjustable legs 25.25" - 26.38" (641.4-670mm)

Stand w/rack supports 22.5" - 23.63" (571.5-600.1mm)

Stand w/rack supports on casters 22.63" (574.7mm)

OVEN CLEARANCES:

Right Side and Rear 6" (152.4mm)

Left Side (with casters) 6" (152.4mm)

Left Side (without casters) 12" (304.9mm)

MINIMUM ENTRY CLEARANCE:

Uncrated 33" (838mm) after adjustment of flue brackets

Crated 42" (1066.8mm)

POWER SUPPLY (per section):

Standard 120VAC, 20 amp, Nema 5-20R dedicated receptacle

Option 208/240VAC, 15 amp, Nema 6-15 dedicated receptacle

Export Export voltages available on request

GAS SUPPLY (per section):

3/4" NPT

Inlet Pressure:

Natural 7.0" W.C. static to unit

Propane 14.0" W.C. static to unit

Maximum Input:

Hot Air 65,000 BTU/hr

Boiler 50,000 BTU/hr

Total Input 115,000 BTU/hr

WATER SUPPLY (per section):

TDS: < 100 ppm Hardness: 80-120 ppm pH: 7.0 - 8.0

Chlorides: < 30 ppm 30(min)-50(max) PSI 140°F (60°C) avg. drain temp.

2" drain connection 3/4" garden hose cold water

Appliance is to be installed with backflow protection in accordance with Federal, State or Local codes.

SHIPPING INFORMATION:

Approx. Weight:

Single section 645 lbs. (293 kg)

Double stack 1320 lbs. (599 kg)

Stand w/guides 140 lbs. (64 kg)

Crate sizes (per section): 44.5" H x 42" W x 54.25" D (1130 x 1067 x 1378mm)

NOTE: The company reserves the right to make substitutions of components without prior notice

BLODGETT COMBI

www.blodgett.com 44 Lakeside Avenue, Burlington, VT 05401 • Toll Free: (800) 331-5842 • Phone: (802) 860-3700 • Fax: (802) 864-0183