

BLCM-202E Roll In Electric Boilerless Combination-Oven/Steamer



OPTIONS AND ACCESSORIES

(AT ADDITIONAL CHARGE)

- Side heat shield
- Additional transport cart
- Wire oven rack
- Right hinge door
- Extra year warranty

OPTIONS AND ACCESSORIES

(AT NO ADDITIONAL CHARGE)

- Optional transport cart with 2.56" (65mm) spacing

Project _____

Item No. _____

Quantity _____

- Standard cart with 3.35" (85mm) spacing holds fifteen full size sheet pans or thirty 12" x 20" x 2-1/2" deep North American hotel pans
- Optional cart with 2.56" (65mm) spacing holds twenty full size sheet pans or forty 12" x 20" x 2" deep Gastronorm pans

Refer to operator manual specification chart for listed model names.

CONSTRUCTION

- 304 Stainless steel exterior and interior
- Dual pane tempered viewing window with hinged inner glass for easy cleaning
- 2" (50mm) fixed drain in the bottom center of cavity
- Door mounted drip tray reduces the risk of wet, slippery floors
- Automatic door stops in positions 110° and 180° for ease of loading and unloading and improved safety.
- Left hinge door is field convertible to the right side (with the purchase of conversion kit)
- Two step safety door latch. The first step stops the fan.

OPERATION

- Multiple cooking modes include hot air, combi 1 (30-40% steam), combi 2 (60-80% steam), retherming, steaming, low-temperature steaming, forced steam, and preheating
- Automated CombiWash, closed circuit cleaning system features very low water and detergent consumption and no contact with chemicals. No proprietary chemicals required, see owner's manual for detergent guidelines.
- Injection steam system - water is injected onto the heating elements, the resulting steam is distributed in the oven chamber by the fan wheel.
- User friendly control with dial and digital display
- Control stores up to 10 recipe programs with 3 cooking stages each
- Reversible 9 speed fan for optimum baking and roasting results
- Programmable time delay start
- 85°-480°F (30°-250°C) temperature range, 575°F (300°C) preheating
- Low water indicator

STANDARD FEATURES

- External core temperature probe with multiple measuring points. User-friendly location reduces strain on the probe.
- Bright halogen lights for superior visibility
- Built in hand shower
- Removeable cleaning chemical bottle shelf
- Transport cart
- Start-up inspection service by factory authorized service agent
- One year parts and labor oven warranty*

* For all international markets, contact your local distributor.



BLODGETT COMBI

www.blodgett.com

44 Lakeside Avenue, Burlington, VT 05401 • Phone: (802) 658-6600 • Fax: (802) 864-0183

BLCM-202E

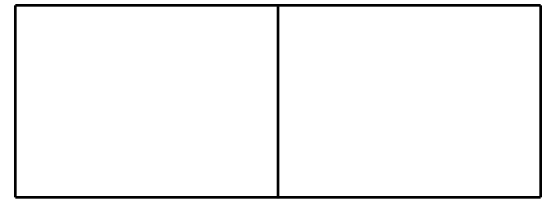

APPROVAL/STAMP

DIMENSIONS ARE IN INCHES (MM)

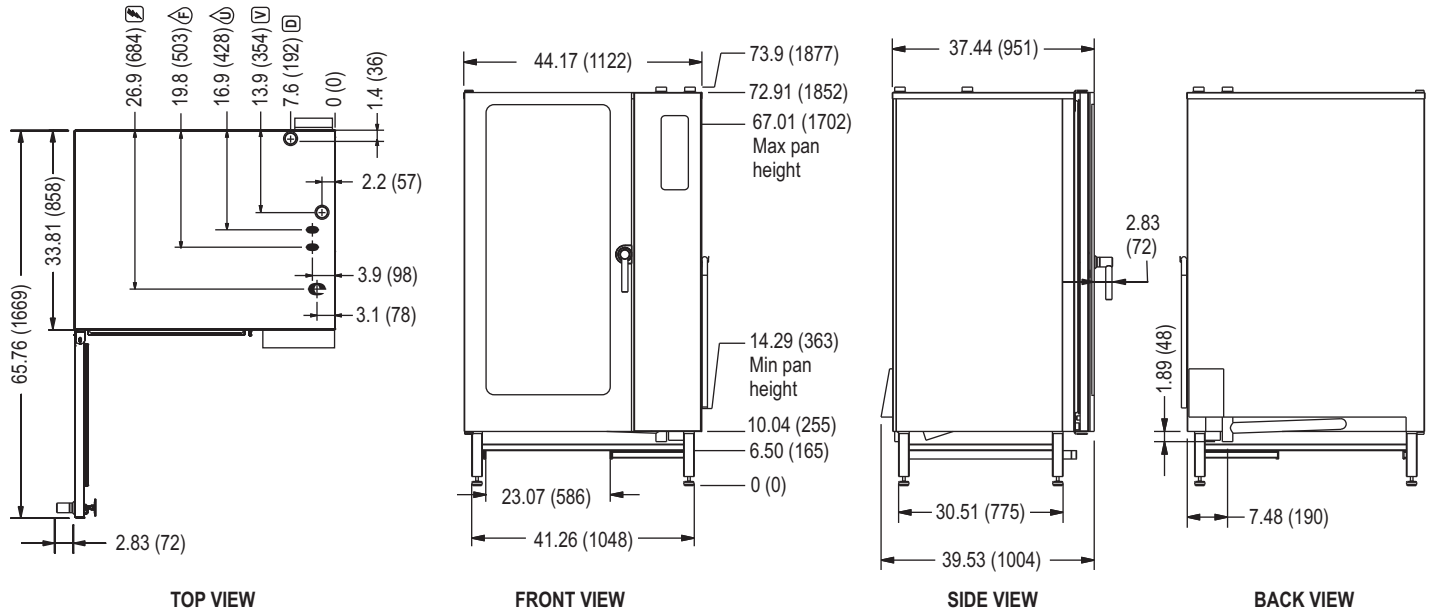

SHORT FORM SPECIFICATIONS: Provide Blodgett Combi model BLCM-202E boilerless combination-oven/steamer. The BLCM-202E has a transport cart with 3.35" (85mm) rack spacing that holds fifteen full size sheet pans or thirty 12" x 20" x 2-1/2" deep North American hotel pans. The optional transport cart with 2.5" (65mm) spacing that holds twenty full size sheet pans or forty 12" x 20" x 2" deep Gastronorm pans. Unit shall have 304 stainless steel exterior and interior. Oven door shall have dual pane tempered viewing window with hinged inner glass for easy cleaning. Multiple cooking modes include hot air, combi 1 (30-40% steam), combi 2 (60-80% steam), reheating/regenerating, steaming, low-temperature steaming, and preheating. Unit shall have the ability to cook with pressureless steam, hot air, or combination of steam and hot air. Unit shall have steam injection system. Unit shall have bright halogen lights for superior visibility. Standard control user friendly digital display with dial, ability to store up to 10 recipe programs with 3 stages per recipe, and time delay start. The reversible 9 speed fan provides optimum baking and roasting results. Automated CombiWash, closed circuit cleaning system features very low water and detergent consumption and no contact with chemicals. One-year parts and labor warranty. Provide start-up inspection service by a factory authorized service agent. Provide options and accessories as indicated.

DIMENSIONS:

Floor space: 44.17" x 37.44" (1122 x 951mm)
Unit height: 73.9" (1877mm)

OVEN CLEARANCES:

From combustible and non-combustible construction

Right 2.75" (70mm)
 Left 2.75" (70mm)
 Back 2" (50mm)

Blodgett recommends 12" clearance from any heat source on the control panel side of the oven, an optional heat shield should be considered.

MINIMUM ENTRY CLEARANCE:

Uncrated 37.44" (951mm)
 Crated 38" (965mm)

NOTE: The company reserves the right to make substitutions of components without prior notice

POWER SUPPLY:

Voltage	KW	Phase	Amperage
208 VAC	60	3	175
240 VAC	60	3	175
480 VAC	60	3	80

Other voltages available - contact factory

WATER SUPPLY:

Good quality water feed is the responsibility of the owner. Water quality must be within the following general guidelines.

TDS: < 100 ppm	Hardness: 80-120 ppm	pH: 7.0 - 8.0
Chlorides: < 30 ppm	30(min)-50(max) PSI	140°F (60°C) avg. drain temp.
2" drain connection	3/4" garden hose cold water	

The best defense against poor water quality is a water filter system designed to meet your water quality conditions. Blodgett offers an optional water filters from Everpure and Terry Corp. for this unit.

Appliance is to be installed with backflow protection in accordance with Federal, State or Local codes.

SHIPPING INFORMATION:

Approx. weight:
 796 lbs. (361 kg)
Crate size:
 81" H x 38" W x 39" D (2057 x 991 x 991mm)

BLODGETT COMBI

www.blodgett.com

44 Lakeside Avenue, Burlington, VT 05401 • Phone: (802) 658-6600 • Fax: (802) 864-0183