



BLCP-202E

Roll In Electric

Boilerless Combination-Oven/Steamer
with Programmable Control



BLCP-202E

Project _____

Item No. _____

Quantity _____

- Standard transport cart with 3.35" (85mm) spacing holds fifteen full size sheet pans or thirty 12" x 20" x 2-1/2" deep North American hotel pans
- Optional transport cart with 2.56" (65mm) spacing holds twenty full size sheet pans or forty 12" x 20" x 2" deep Gastronorm pans

Refer to operator manual specification chart for listed model names.

CONSTRUCTION

- 304 stainless steel exterior and interior
- Dual pane tempered viewing window with hinged inner glass for easy cleaning
- 2" (50mm) fixed drain in the bottom center of cavity
- Door mounted drip tray reduces the risk of wet, slippery floors
- Automatic door stops in positions of 110° and 180°
- Left hinge door is field convertible to the right side (with the purchase of conversion kit)
- Two step safety door latch. The first step stops the fan.

OPERATION

- Injection steam system - water is injected onto the heating elements, the resulting steam is distributed in the oven chamber by the fan wheel.
- Multiple cooking modes include hot air, CombiOptima, retherm, steaming, low-temperature steaming, forced steaming, proofing, cooling, and preheating
- CombiOptima automatically measures and controls the humidity level in the oven, helping to retain the appearance and juiciness of the product.
- Automated CombiWash, closed circuit cleaning system features very low water and detergent consumption and no contact with chemicals. No proprietary chemicals required, see owner's manual for detergent guidelines.
- Crystal clear TFT display with touch pad control
- Stores up to 200 recipe programs with 10 cooking stages each. Recipes can be grouped into fifteen categories (beef, chicken, cookies, etc.) for easy retrieval.
- Ability to run 2 core probes simultaneously
- Low temperature roast & hold and Delta-T cooking
- Reversible 9 speed fan for optimum baking and roasting results
- USB port for data and recipe transfer
- HACCP recording and documentation
- Programmable time delay start
- 85°-480°F (30°-250°C) temperature range, 575°F (300°C) preheating
- Automatic service diagnosis
- Low water indicator

STANDARD FEATURES

- External core temperature probe with multiple measuring points.
- Bright halogen lights for superior visibility
- Built in hand shower
- Removeable cleaning chemical bottle shelf
- Adjustable feet
- Transport cart
- Start-up inspection service by factory authorized service agent
- One year parts and labor oven warranty*

* For all international markets, contact your local distributor.

OPTIONS AND ACCESSORIES

(AT ADDITIONAL CHARGE)

- Additional core probe
- Heat shield
- Additional transport cart
- Wire oven rack
- Right hinge door
- Extra year warranty

OPTIONS AND ACCESSORIES

(AT NO ADDITIONAL CHARGE)

- Optional transport cart with 2.56" (65mm) spacing



BLODGETT COMBI

www.blodgett.com

44 Lakeside Avenue, Burlington, VT 05401 • Phone: (802) 658-6600 • Fax: (802) 864-0183

BLCP-202E

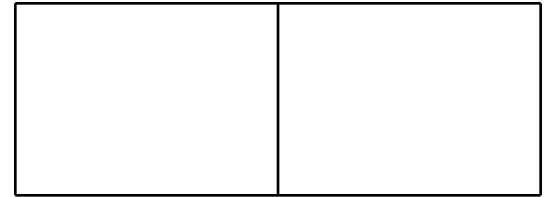

APPROVAL/STAMP

DIMENSIONS ARE IN INCHES (MM)

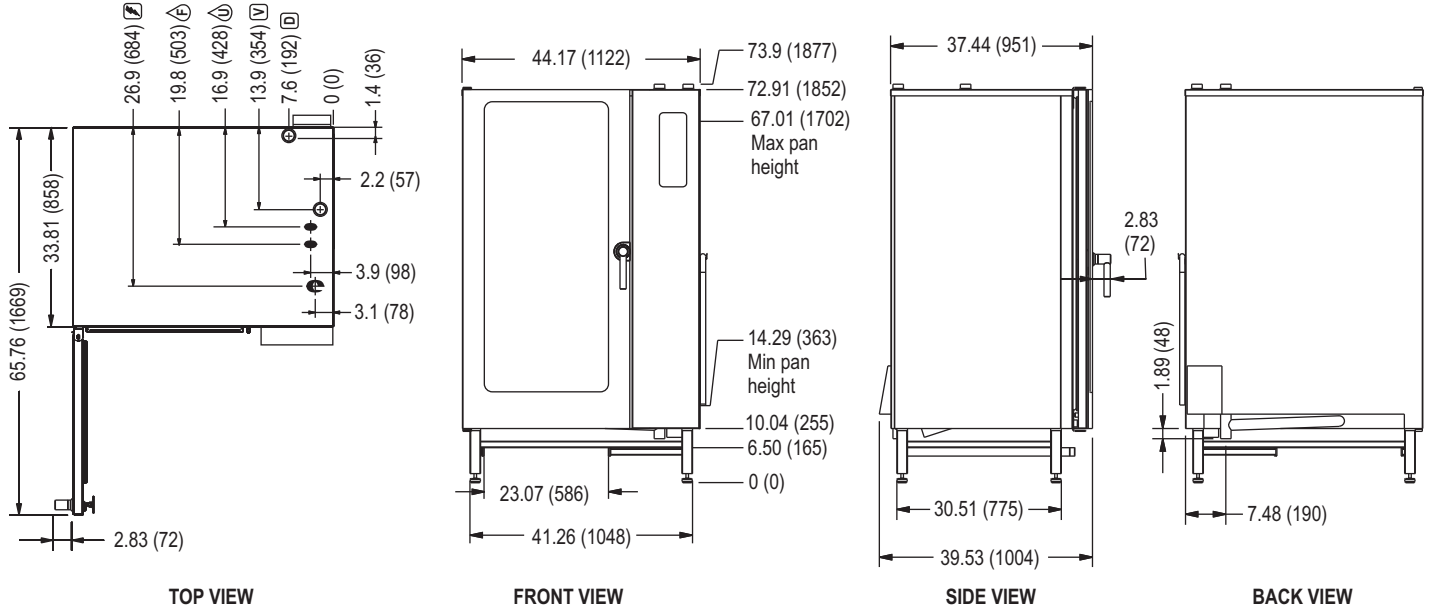

SHORT FORM SPECIFICATIONS: Provide Blodgett Combi model BLCP-202E boilerless combination-oven/steamer. The BLCP-202E has a transport cart with 3.35" (85mm) vertical spacing that holds fifteen full size sheet pans or thirty 12" x 20" x 2-1/2" deep North American hotel pans. The optional transport cart with 2.5" (65mm) vertical spacing holds twenty full size sheet pans or forty 12" x 20" x 2" deep Gastronorm pans. Unit shall have 304 stainless steel exterior and interior. Oven door shall have dual pane tempered viewing window with hinged inner glass. Unit shall have the ability to cook with pressureless steam, hot air, or combination of steam and hot air. Steam generator shall be separate from the cooking compartment and shall drain and flush automatically. Multiple cooking modes include hot air, combi with CombiOptima, reheating/ regenerating, steaming, low-temperature steaming, forced steaming, proofing, cooling, and preheating. Unit shall have halogen lights for superior visibility. Programmable control features crystal clear TFT display, ability to store up to 200 recipe programs with 10 cooking stages per program, recipes can be stored under categories for easy retrieval. Control also features programmable time delay start, delta-T cooking, USB connection to upload and download product recipes and CombiOptima automatic humidity control. HACCP control enables you to control and document production, data includes: production time, duration, oven temperature, and core temperature. CombiNet for monitoring and remote-controlling the oven via computer or internet, functions include: recipe management, HACCP, service diagnosis and software updating. The reversible 9 speed fan provides optimum baking and roasting results. Automated CombiWash, closed circuit cleaning system features very low water and detergent consumption and no contact with chemicals. One-year parts and labor warranty. Provide start-up inspection service by a factory authorized service agent prior to operating the oven. Provide options and accessories as indicated.

DIMENSIONS:

Floor space: 44.17" x 37.44" (1122 x 951mm)
Unit height: 73.9" (1877mm)

OVEN CLEARANCES:

From combustible and non-combustible construction
 Right 2.75" (70mm)
 Left 2.75" (70mm)
 Back 2" (50mm)

Blodgett recommends 12" clearance from any heat source on the control panel side of the oven, an optional heat shield should be considered.

MINIMUM ENTRY CLEARANCE:

Uncrated 37.47" (951mm)
 Crated 38" (965mm)

SHIPPING INFORMATION:

Approx. weight: 796 lbs. (361 kg)
Crate size: 81" H x 38" W x 39" D (2057 x 991 x 991mm)

POWER SUPPLY:

Voltage	KW	Phase	Amperage
208 VAC	60	3	175
240 VAC	60	3	175
480 VAC	60	3	80

Other voltages available - contact factory

WATER SUPPLY:

Good quality water feed is the responsibility of the owner. Water quality must be within the following general guidelines.
 TDS: < 100 ppm Hardness: 80-120 ppm pH: 7.0 - 8.0
 Chlorides: < 30 ppm 30(min)-50(max) PSI 140°F (60°C) avg. drain temp.
 2" drain connection 3/4" garden hose cold water

The best defense against poor water quality is a water filter system designed to meet your water quality conditions. Blodgett offers an optional water filters from Everpure and Terry Corp. for this unit.

Appliance is to be installed with backflow protection in accordance with Federal, State or Local codes.

NOTE: The company reserves the right to make substitutions of components without prior notice.