



## BCX-14G and DFG-200

BCX Series Combi Stacked on a Full-Size Gas Convection Oven



Shown with optional casters

### DFG-200 OPTIONS AND ACCESSORIES

(AT ADDITIONAL CHARGE)

- **Gas hose with quick disconnect and restraining device:**
  - 48" (1219mm) hose
  - 36" (914mm) hose
- Solid state digital control with LED display, cook and hold, and Pulse Plus®
- Stainless steel oven liner
- 6" (152mm) casters
- Extra oven racks
- Stainless steel solid back panel
- Prison package (includes security control panel and stainless steel back)
- Security control panel
- Flue connector

### OPTIONS AND ACCESSORIES

(AT NO ADDITIONAL CHARGE)

- Solid stainless steel doors

Project \_\_\_\_\_

Item No. \_\_\_\_\_

Quantity \_\_\_\_\_

Requires Blodgett stacking kit SK-88FS.

## DFG-200 SPECIFICATIONS

### EXTERIOR CONSTRUCTION

- Full angle-iron frame
- Stainless steel front, top, and sides
- Dual pane thermal glass windows encased in stainless steel door frames
- Porcelain door handle with simultaneous door operation
- Triple-mounted pressure lock door design with turnbuckle assembly
- Modular slide out front control panel for easy access
- Solid mineral fiber insulation at top, back, sides and bottom

### INTERIOR CONSTRUCTION

- Double-sided porcelainized baking compartment liner (14 gauge) for easy cleaning
- Aluminized steel combustion chamber
- Dual inlet blower wheel
- Five chrome-plated racks, eleven rack positions with a minimum of 1-5/8" (41 mm) spacing

### OPERATION

- Dual Flow Gas system combines direct and indirect heat
- Electronic spark ignition control system
- Removable dual tube burners
- Pressure regulator
- Manual gas service cut-off switch on the front of the control panel
- Air mixers with adjustable air shutters
- Solid state thermostat with temperature control range of 200°F (93°C) to 500°F (260°C)
- Two speed fan motor (60 Hz only, not available in 50 Hz)\*
- 1/3 horsepower blower motor with automatic thermal overload protection
- Control area cooling fan
- Two 50 watt commercial bake oven lamps

### CAPACITY

- Extra depth baking compartment - accepts five 18" x 26" standard full-size baking pans in left-to-right or front-to-back positions.

### STANDARD FEATURES

- Solid state manual with separate dials to control thermostat and timer
- 6" (152mm) adjustable stainless steel legs
- Two year oven parts and one year labor warranty\*
- Five year limited oven door warranty\*

\* For all international markets, contact your local distributor.



### BLODGETT OVEN COMPANY

www.blodgett.com

44 Lakeside Avenue, Burlington, VT 05401 • Toll Free: (800) 331-5842  
Phone: (802) 860-3700 • Fax: (802) 864-0183

BCX-14G STACKED ON A DFG-200



## BCX-14G and DFG-200

BCX Series Combi Stacked on a Full-Size Gas Convection Oven



Shown with optional casters

### BCX-14G COMBI OPTIONS AND ACCESSORIES

(AT ADDITIONAL CHARGE)

- MenuSelect control can hold multi-stage programming for up to 99 products, includes Cook & Hold and core probe cooking
- Water pressure regulator
- Additional 6-1/2" core temperature probe
- Additional stainless steel wire shelves
- Chicken roasting rack
- Single source water manifold
- Extended warranty

### OPTIONS AND ACCESSORIES

(AT NO CHARGE)

- LP gas
- 208/240 volt

## BCX-14G COMBI SPECIFICATIONS

### EXTERIOR CONSTRUCTION

- Stainless steel top, front and sides
- Dual pane tempered viewing window with hinged inner glass for easy cleaning
- Door mounted condensate trough
- Top and bottom mount, easily adjustable door hinges
- Pivot out user interface panel for service access

### INTERIOR CONSTRUCTION

- Fully welded stainless steel frame
- Fully insulated cooking chamber
- Fixed drain bottom center of cavity
- Easily removable stainless steel side rails
- Coved corner liner for ease of cleaning

### OPERATION

- Standard control with function selection for steam, combi, hot air and cool down
- Retherm band on control
- Steam on demand feature
- Thermostat control to 500F
- Multiple speed reversing fan for even bake
- Dual stage door latch to vent steam before fully opening door
- Cavity vent control provides ability to release steam at the turn of a switch
- Integral door switch
- Electronic spark ignition
- Open vented system. Condenses steam and drains away by-products of the cooking process, eliminates flavor transfer
- Self contained, self-flushing steam generator separate from cooking compartment for instant steam recovery when switching modes
- Control prompts user to delime when steam generator requires deliming

### CAPACITY

- Fourteen 12" x 20" x 2-1/2" deep pans at 3-1/4" spacing
- Seven 18" x 26" deep pans at 3-1/4" spacing

### STANDARD FEATURES

- Five (5) stainless steel wire shelves per section (capacity for 7)
- Hinged pressure panel for cleanability
- Four halogen lights for superior cavity illumination
- Retractable hose reel hidden behind door, no extraneous hoses
- Stacking kit and casters for double stack ovens
- Semi-auto delime system
- Deliming bottle assembly
- Pressure spray bottle for oven cleaning
- 6-1/2" core temperature probe
- Start-up inspection service by factory authorized service agent
- One year parts and labor oven warranty\*

\* For all international markets, contact your local distributor.



### BLODGETT OVEN COMPANY

www.blodgett.com

44 Lakeside Avenue, Burlington, VT 05401

Toll Free: (800) 331-5842 • Phone: (802) 860-3700 • Fax: (802) 864-0183

BCX-14G STACKED ON A DFG-200



## BCX-14G STACKED ON A DFG-200

DIMENSIONS ARE  
IN INCHES (MM)

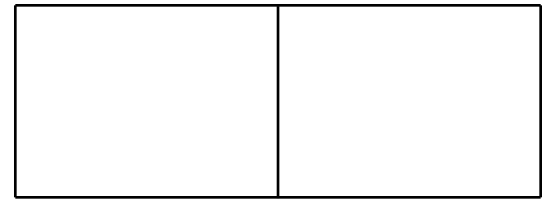
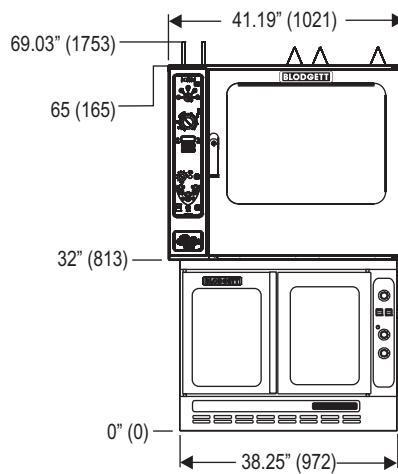
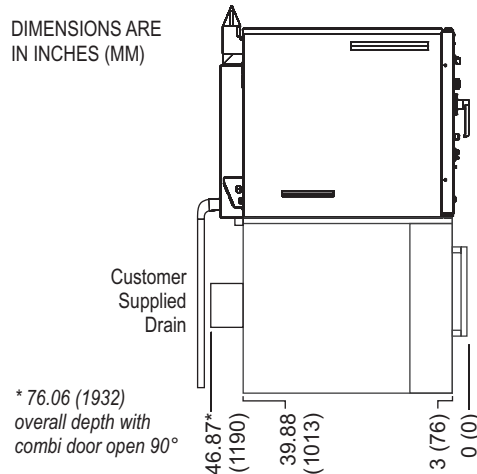

### APPROVAL/STAMP

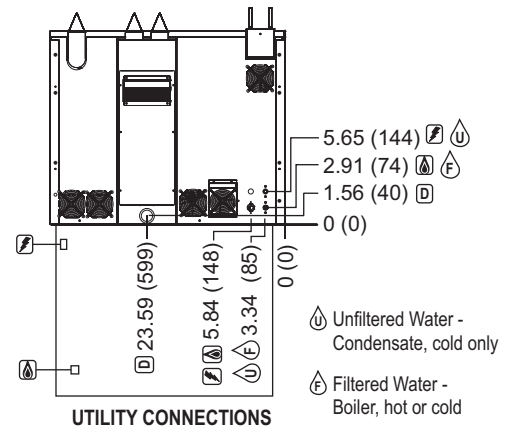

Unfiltered Water - Condensate, cold only  
 Filtered Water - Boiler, hot or cold

### SHORT FORM SPECIFICATIONS

Provide Blodgett model BCX-14G gas combination-oven/steamer stacked on a model DFG-200 full-size convection oven.

**BC-14G Combi** - Unit shall have the ability to cook with pressureless steam (212F), hot air, or combination of steam and hot air (with an operating range 140F to 500F), vario-steaming (operating range 140F to 212F), low temperature cooking and holding, rethermalizing, cool down mode and our Exclusive Steam on Demand steam injection system. Oven capacity to accept 7ea 18x26 bake pans or 14ea 12x20x2.5" full size steam table pans with 3-1/4" spacing. Front access service user interface control panel and service diagnosis system. Unit shall be constructed with a fully welded stainless steel frame. Cooking chamber shall be constructed with 304 series with bright-annealed stainless steel finish and coved corners. Integrated retractable wash down hose to include front water shut off valve. Oven cavity shall be open to the atmosphere with a thermostatically controlled quench box with a flow rate of less than 8 gallons per hour (total water consumption not to exceed 15 gallons per hour). Unit shall include a four speed, bi-directional fan with vent switch to control humidity in the cooking chamber. Dual pane thermal glass window with 180 degree door swing, two-step safety door-latch with adjustable door hinges, door mounted drip pan. Unit to include a detachable 6-1/2" core temperature probe and four halogen lights. Supply with exclusive time to delime indicator with adjustable settings of 30, 60 or 90 hours of run time, semi-automatic deliming system. Where applicable, quantities in this spec are doubled for stacked units. A start-up inspection service will be performed by our factory-authorized agent at no cost to the operator. One-year parts and labor warranty, standard.

**DFG-200** - Shall have (porcelainized/stainless) steel liner and shall accept five 18" x 26" standard full-size bake pans in left-to-right or front-to-back positions. Stainless steel front, top and sides. Doors shall (be solid stainless steel/have dual pane thermal glass windows) with single porcelain handle and simultaneous operation. Unit shall be gas heated with electronic spark ignition and shall cook by means of a dual-flow system combining direct and indirect heat and a gas shutoff switch on the front of the control panel. Air in baking chamber distributed by dual inlet blower wheel powered by a two-speed, 1/3 HP motor with thermal overload protection. Each chamber shall be fitted with two commercial lamps and five chrome-plated removable racks. Control panel shall be recessed with Cook/Cool Down mode selector, solid state (manual/digital) infinite thermostat (200- 500° F), and 60 minute timer.

Provide options and accessories as indicated.

### DIMENSIONS:

**Product clearance** 6" from combustible and non-combustible construction. 12" on left side if not on casters.

**Additional Height:** 6" adjustable legs 6-7/8" - 8" (174.6-203.2mm)

GAS SUPPLY:	BCX-14G	DFG-200
<b>Connection:</b>	3/4" NPT	3/4" NPT
<b>Inlet Pressure:</b>		
Natural	7.0" W.C.	7.0" W.C. minimum 10.5" W.C. maximum
Propane	14.0" W.C.	11.05" W.C. minimum 13.0" W.C. maximum

Manifold Pressure:	BCX-14G	DFG-200
Natural	3.5 W.C.	3.5 W.C.
Propane	10.0 W.C.	10.0 W.C.
<b>Maximum Input:</b>	115,000 BTU/hr	60,000 BTU/hr

### WATER SUPPLY (BCX-14G only):

TDS: < 100 ppm Hardness: 80-120 ppm pH: 7.0 - 8.0

Chlorides: < 30 ppm 30(min)-50(max) PSI

140°F (60°C) avg. drain temp.

2" drain connection 3/4" garden hose cold water

Appliance is to be installed with backflow protection in accordance with Federal, State or Local codes.

### POWER SUPPLY:

BCX-14G:	120VAC, 20 amp, Nema 5-20R dedicated receptacle
DFG-200:	3-wire, 6 Amp, 115 VAC, 1 phase, 60 Hz. 1/3 H.P., 2 speed motor, 1140 and 1725 RPM
	2-wire, 3 Amp, 230VAC CE model, 1 phase, 50 Hz. 1/3 H.P., 1 speed motor, 1425 RPM
	6' (1.8m) electric cord set furnished
Both units:	Each unit requires a dedicated circuit.

### MINIMUM ENTRY CLEARANCE:

	BCX-14G	DFG-200
Uncrated	33" (838mm)*	32-1/16" (814mm)
Crated	42" (1066.8mm)	37-1/2" (953mm)

\* after adjustment of flue brackets

### SHIPPING INFORMATION:

#### Approx. Weight:

BCX-14G 645 lbs. (293 kg)

DFG-200 650 lbs. (295 kg)

#### Crate sizes (per section):

BCX-14G 44.5" H x 42" W x 54.25" D (1130 x 1067 x 1378mm)

DFG-200 37-1/2" (952mm) x 43-1/2" (1105mm) x 52" (1321mm)

**NOTE:** The company reserves the right to make substitutions of components without prior notice

### BLODGETT OVEN COMPANY

www.blodgett.com • 44 Lakeside Avenue, Burlington, VT 05401 • Toll Free: (800) 331-5842 • Phone: (802) 860-3700 • Fax: (802) 864-0183