



B14-G & ZEPHAIRE-G PLUS

Boilerless Combi Stacked on a Full-Size Gas Convection Oven



Shown with optional casters

ZEPHAIRE G PLUS OPTIONS AND ACCESSORIES (AT ADDITIONAL CHARGE)

- Gas hose with quick disconnect and restraining device:
 - 48" (1219mm) hose
 - 36" (914mm) hose
- 6" (152mm) casters
- Extra oven racks
- Stainless steel solid back panel

OPTIONS AND ACCESSORIES (AT NO ADDITIONAL CHARGE)

- Solid stainless steel doors

Project _____

Item No. _____

Quantity _____

Requires Blodgett stacking kit KS-88FS.

ZEPHAIRE G PLUS SPECIFICATIONS

EXTERIOR CONSTRUCTION

- Full angle iron frame
- Stainless steel front, top, sides and legs
- Dual pane thermal glass windows encased in stainless steel door frames
- Porcelain door handle with simultaneous door operation
- Triple-mounted pressure lock door design with turnbuckle assembly
- Removable front control panel
- Solid mineral fiber insulation at top, back, sides and bottom

INTERIOR CONSTRUCTION

- Double-sided porcelainized baking compartment liner (14 gauge)
- Aluminized steel combustion chamber
- Dual inlet blower wheel
- Five chrome-plated racks, eleven rack positions with a minimum of 1-5/8"(41mm) spacing

OPERATION

- Dual Flow Gas system combines direct and indirect heat
- Electronic spark ignition control system
- Removable dual tube burners
- Pressure regulator and manual gas service cut-off valve located in front control area
- Air mixers with adjustable air shutters
- Solid state thermostat with temperature control range of 200°F (93°C) to 500°F (260°C)
- 60 minute electric timer with buzzer
- Two speed fan motor
- 1/3 horsepower blower motor with automatic thermal overload protection
- Control area cooling fan
- Two 50 watt commercial bake oven lamps

CAPACITY

- Extra depth baking compartment - accepts five 18" x 26" standard full-size baking pans in left-to-right or front-to-back positions.

STANDARD FEATURES

- 6" (152mm) adjustable stainless steel legs
- One year parts and labor oven warranty*
- Three year limited oven door warranty*

* For all international markets, contact your local distributor.

B14-G STACKED ON A ZEPHAIRE-G PLUS



BLODGETT COMBI
www.blodgett.com

44 Lakeside Avenue, Burlington, VT 05401 • Phone: (802) 658-6600 • Fax: (802) 864-0183



B14-G & ZEPHAIRE-G PLUS

Boilerless Combi Stacked on a Full-Size Gas Convection Oven



Shown with optional casters

B14-G COMBI OPTIONS AND ACCESSORIES

(AT ADDITIONAL CHARGE)

- Locking control panel
- Locking door hasp
- Tamper proof screws
- Additional stainless steel wire shelves
- Stainless steel back panel
- Chicken roasting rack
- Extended warranty

OPTIONS AND ACCESSORIES

(AT NO CHARGE)

- LP gas

B14-G COMBI SPECIFICATIONS

EXTERIOR CONSTRUCTION

- Stainless steel top, front, sides and right hand door hinge
- Aluminized steel bottom
- Single pane tempered viewing window
- Door mounted condensate trough
- Well protected control panel
- Side mount, easily adjustable door hinges
- Roll out control panel exposes most serviceable parts

INTERIOR CONSTRUCTION

- Fully welded stainless steel frame
- Fully insulated cooking chamber
- 316 stainless steel oven cavity
- Fixed drain bottom center of cavity
- Filterless grease slinging convection fan
- Easily removable stainless steel side rails

OPERATION

- Boilerless steam generation
- Standard control with four function selection switch for steam, hot air, combined steam/hot air, cool down, Vario Steam® and steam on demand feature
- Solid state rotary dial thermostat - range 150-500°F (66-260°C)
- Motor driven 120 minute timer shuts down at elapsed time
- Two speed fan
- Magnetic door interlock switch shuts off oven when door is opened
- Electronic ignition
- Open vented system. Condenses steam and drains away by-products of the cooking process, eliminates flavor transfer
- 11 rack positions with 1-5/8" (41mm) spacing
- Oven clean light
- Wall mounted filter system - Carbon Block and Scale Inhibitor

CAPACITY

- Fourteen 12" x 20" x 2-1/2" deep pans at 3-1/4" spacing
- Seven 18" x 26" deep pans at 3-1/4" spacing

STANDARD FEATURES

- Five (5) stainless steel wire shelves per section (capacity for 7)
- Pressure spray bottle for oven cleaning
- Hose and spray assembly for interior cleaning
- Water pressure regulator (1 per section)
- Drain kit assembly
- Start-up inspection service by factory authorized service agent
- One year parts and labor oven warranty



BLODGETT COMBI

www.blodgett.com

44 Lakeside Avenue, Burlington, VT 05401 • Phone: (802) 658-6600 • Fax: (802) 864-0183

B14-G STACKED ON A ZEPHAIRE-G PLUS



B14-G STACKED ON A ZEPHAIRE-G PLUS

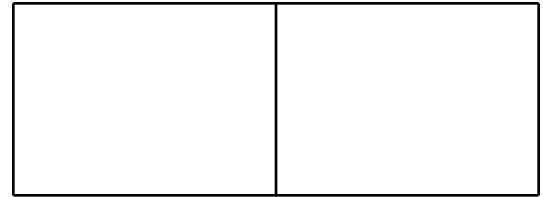

APPROVAL/STAMP

DIMENSIONS ARE IN INCHES (MM)

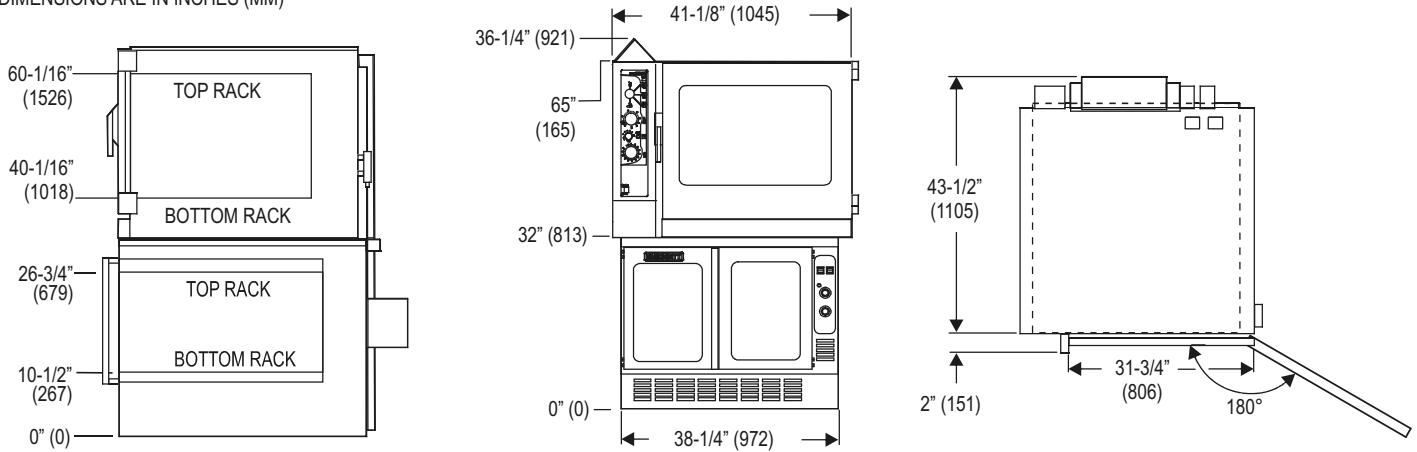

SHORT FORM SPECIFICATIONS

Provide Blodgett model B14-G gas boilerless combination-oven/steamer stacked on a model ZEPHAIRE PLUS full-size convection oven.

B14-G Combi - Unit shall have the ability to cook with pressureless steam, hot air, or combination of steam and hot air. Mechanical mode switch shall allow the operator to choose four modes, steam, hot air, combi or cool down mode. Timer to be 120 minute motor driven. Temperature control to be solid state with rotary knob. Unit shall include two speed fan, steam on demand feature and Vario Steam® feature. The interior shall have the capability of being hosed down for cleaning. Door gaskets shall be easily removable for replacement and cleaning. Unit shall be open vented for waist air quenching. A start-up inspection service will be performed by our factory authorized agent at no cost to the operator.

Zephaire G Plus - Shall have porcelainized steel liner and shall accept five 18" x 26" standard full-size bake pans in left-to-right or front-to-back positions. Doors shall have dual pane thermal glass windows with single porcelain handle and simultaneous operation. Unit shall be gas heated with electronic spark ignition and shall cook by means of a dual-flow system combining direct and indirect heat. Air in baking chamber distributed by dual inlet blower wheel powered by a two speed, 1/3 HP motor with thermal Overload protection. Each chamber shall be fitted with five chrome-plated removable racks. Control panel shall be recessed with Cook/Cool Down mode selector, solid state manual infinite thermostat (200 - 500°F), and 60-minute timer.

Provide options and accessories as indicated.

DIMENSIONS:

Product clearance 6" from combustible and non-combustible construction. 12" on left side if not on casters.

Additional Height:
6" adjustable legs 6-7/8" - 8" (174.6-203.2mm)

MINIMUM ENTRY CLEARANCE:

	B-14G	Zephaire G Plus
Uncrated	36-1/4" (921mm)	32-1/16" (814mm)
Crated	42" (1066.8mm)	37-1/2" (953mm)

POWER SUPPLY:

B14-G:	115 VAC, 10 amp, 1 phase, 60 Hz., 2-wire with ground
Zephaire G Plus:	115 VAC, 6 amp, 1 phase, 60 Hz., 2-wire with ground
Both units:	6' (1.8m) electric cord set furnished. Each unit requires a dedicated 15 amp. circuit.

GAS SUPPLY:

	B14-G	Zephaire G Plus
Connection:	3/4" NPT	3/4" IPS
Inlet Pressure:		
Natural	7.0" W.C.	7.0" W.C. minimum 10.5" W.C. maximum
Propane	14.0" W.C.	10.5" W.C. minimum 13.0" W.C. maximum

Manifold Pressure:

Natural	N/A	3.5 W.C.
Propane	N/A	10.0 W.C.
Maximum Input:	65,000 BTU/hr	60,000 BTU/hr

WATER SUPPLY (B14-G only):

Water Quality Requirements	
TDS: < 100 ppm	Hardness: 80-120 ppm
pH: 7.0 - 8.0	Chlorides: < 30 ppm
Max. Water Temp: 100°F (38°C)	3/4" hose cold water
30(min)-50(max) PSI	2" drain connection
Distance from filter to oven: 7' maximum	
Filter weight (when full): 12 lbs	
8' hoses to connect oven to filter are supplied	

SHIPPING INFORMATION:

Approx. Weight:

B14-G	680 lbs. (309 kg)
Zephaire G Plus	640 lbs. (290 kg)

Crate sizes (per section):

B14-G	53" H x 45" W x 42" D (1346.2 x 1143 x 1066.8mm)
Zephaire G Plus	37-1/2" (952mm) x 43-1/2" (1105mm) x 52" (1321mm)

NOTE: The company reserves the right to make substitutions of components without prior notice

BLODGETT COMBI

www.blodgett.com

44 Lakeside Avenue, Burlington, VT 05401
Phone: (802) 658-6600 • Fax: (802) 864-0183