



**BC-14G and ZEPHAIRE-G PLUS**  
Synergy Combi Stacked on a Full-Size Gas Convection Oven



*Shown with optional casters*

**ZEPHAIRE G PLUS**  
**OPTIONS AND ACCESSORIES**

(AT ADDITIONAL CHARGE)

- **Gas hose with quick disconnect and restraining device:**
  - 48" (1219mm) hose
  - 36" (914mm) hose
- 6" (152mm) casters
- Extra oven racks
- Stainless steel solid back panel

**OPTIONS AND ACCESSORIES**

(AT NO ADDITIONAL CHARGE)

- Solid stainless steel doors

Project \_\_\_\_\_

Item No. \_\_\_\_\_

Quantity \_\_\_\_\_

*Requires Blodgett stacking kit KS-88FS.*

**ZEPHAIRE G PLUS SPECIFICATIONS**

**EXTERIOR CONSTRUCTION**

- Full angle iron frame
- Stainless steel front, top, sides and legs
- Dual pane thermal glass windows encased in stainless steel door frames
- Porcelain door handle with simultaneous door operation
- Triple-mounted pressure lock door design with turnbuckle assembly
- Removable front control panel
- Solid mineral fiber insulation at top, back, sides and bottom

**INTERIOR CONSTRUCTION**

- Double-sided porcelainized baking compartment liner (14 gauge)
- Aluminized steel combustion chamber
- Dual inlet blower wheel
- Five chrome-plated racks, eleven rack positions with a minimum of 1-5/8"(41mm) spacing

**OPERATION**

- Dual Flow Gas system combines direct and indirect heat
- Electronic spark ignition control system
- Removable dual tube burners
- Pressure regulator and manual gas service cut-off valve located in front control area
- Air mixers with adjustable air shutters
- Solid state thermostat with temperature control range of 200°F (93°C) to 500°F (260°C)
- 60 minute electric timer with buzzer
- Two speed fan motor
- 1/3 horsepower blower motor with automatic thermal overload protection
- Control area cooling fan
- Two 50 watt commercial bake oven lamps

**CAPACITY**

- Extra depth baking compartment - accepts five 18" x 26" standard full-size baking pans in left-to-right or front-to-back positions.

**STANDARD FEATURES**

- 6" (152mm) adjustable stainless steel legs
- One year parts and labor oven warranty\*
- Three year limited oven door warranty\*

\* For all international markets, contact your local distributor.



**BC-14G STACKED ON A ZEPHAIRE-G PLUS**

**BLODGETT COMBI**

www.blodgett.com

44 Lakeside Avenue, Burlington, VT 05401 • Phone: (802) 658-6600 • Fax: (802) 864-0183



**BC-14G and  
ZEPHAIRE-G PLUS**  
Synergy Combi Stacked on a  
Full-Size Gas Convection Oven



*Shown with optional casters*

**BC-14G COMBI  
OPTIONS AND ACCESSORIES**

(AT ADDITIONAL CHARGE)

- Semi-Automatic Deliming pump that installs directly to the back of the unit with delivery hose and delimiting container
- Programmable digital controls with cook and hold and Vario Steam®
- Locking control panel
- Locking door hasp
- Tamper proof screws
- Additional stainless steel wire shelves
- Core temperature probe with digital readout
- Stainless steel back panel
- Chicken roasting rack
- Hot water/filtered water connection kit
- Extended warranty

**OPTIONS AND ACCESSORIES**

(AT NO CHARGE)

- LP gas
- 208/240 volt

**BC-14G COMBI SPECIFICATIONS**

**EXTERIOR CONSTRUCTION**

- Stainless steel top, front, sides and right hand door hinge
- Single pane tempered viewing window
- Door mounted condensate trough
- Well protected control panel
- Side mount, easily adjustable door hinges
- Roll out control panel exposes most serviceable parts
- Modular controls allow for field upgrade to digital controls

**INTERIOR CONSTRUCTION**

- Fully welded stainless steel frame
- Fully insulated cooking chamber
- Fixed drain bottom center of cavity
- Filterless grease slinging convection fan
- Easily removable stainless steel side rails

**OPERATION**

- Standard control with four function selection switch for steam, hot air, combined steam/hot air, cool down, Vario Steam® and steam on demand feature
- Solid state rotary dial thermostat - range 150-500°F (66-260°C)
- Motor driven 120 minute timer shuts down at elapsed time
- Two speed fan
- Magnetic door interlock switch shuts off oven when door is opened
- Electronic ignition
- Open vented system. Condenses steam and drains away by-products of the cooking process, eliminates flavor transfer
- Self contained, self-flushing steam generator separate from cooking compartment for instant steam recovery when switching modes
- Delimiting light flashes when steam generator requires delimiting
- Delimiting container with manual pump for storing and dispensing delimiting solution. (See automatic delimiting option)

**CAPACITY**

- Fourteen 12" x 20" x 2-1/2" deep pans at 3-1/4" spacing
- Seven 18" x 26" deep pans at 3-1/4" spacing

**STANDARD FEATURES**

- Five (5) stainless steel wire shelves per section (capacity for 7)
- Delimiting bottle and pump assembly
- Pressure spray bottle for oven cleaning
- Hose and spray assembly for interior cleaning
- Two speed fan
- Water pressure regulator (1 per section)
- Drain kit assembly
- Start-up inspection service by factory authorized service agent
- One year parts and labor oven warranty



**BLODGETT COMBI**

[www.blodgett.com](http://www.blodgett.com)

44 Lakeside Avenue, Burlington, VT 05401

Phone: (802) 658-6600 • Fax: (802) 864-0183

**BC-14G STACKED ON A ZEPHAIRE-G PLUS**



# BC-14G STACKED ON A ZEPHAIRE-G PLUS

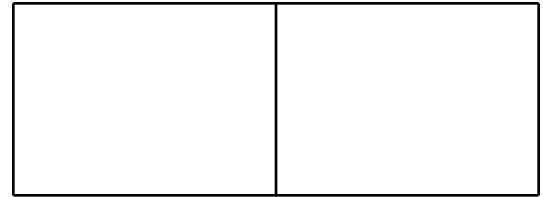

APPROVAL/STAMP

DIMENSIONS ARE IN INCHES (MM)

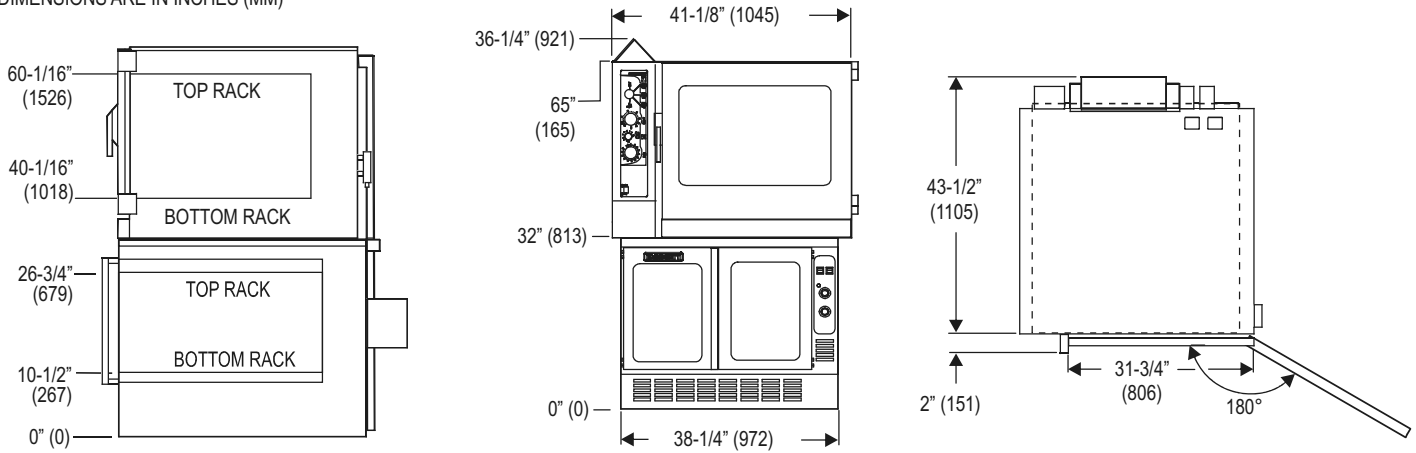

### SHORT FORM SPECIFICATIONS

Provide Blodgett model BC-14G gas synergy combination-oven/steamer stacked on a model ZEPHAIRE PLUS full-size convection oven.

**BC-14G Combi** - Unit shall have the ability to cook with pressureless steam, hot air, or combination of steam and hot air. Mechanical mode switch shall allow the operator to choose four modes, steam, hot air, combi or cool down mode. Timer to be 120 minute motor driven. Temperature control to be solid state with rotary knob. Unit shall include two speed fan, steam on demand feature, delimiting indicator light and Vario Steam® feature. The interior shall have the capability of being hosed down for cleaning. Door gaskets shall be easily removable for replacement and cleaning. Unit shall be open vented for waist air quenching. Steam generator shall be separate from the cooking compartment in order to provide the fastest possible steam recovery. Steam generator shall flush automatically to cut down on mineral build up. A start-up inspection service will be performed by our factory authorized agent at no cost to the operator.

**Zephaire G Plus** - Shall have porcelainized steel liner and shall accept five 18" x 26" standard full-size bake pans in left-to-right or front-to-back positions. Doors shall have dual pane thermal glass windows with single porcelain handle and simultaneous operation. Unit shall be gas heated with electronic spark ignition and shall cook by means of a dual-flow system combining direct and indirect heat. Air in baking chamber distributed by dual inlet blower wheel powered by a two speed, 1/3 HP motor with thermal Overload protection. Each chamber shall be fitted with five chrome-plated removable racks. Control panel shall be recessed with Cook/Cool Down mode selector, solid state manual infinite thermostat (200 - 500°F), and 60-minute timer.

Provide options and accessories as indicated.

### DIMENSIONS:

**Product clearance** 6" from combustible and non-combustible construction. 12" on left side if not on casters.

**Additional Height:**  
6" adjustable legs 6-7/8" - 8" (174.6-203.2mm)

### MINIMUM ENTRY CLEARANCE:

	BC-14G	Zephaire G Plus
Uncrated	36-1/4" (921mm)	32-1/16" (814mm)
Crated	42" (1066.8mm)	37-1/2" (953mm)

### POWER SUPPLY:

BC-14G:	120VAC 15 amp Nema 5-15 receptacle
Zephaire G Plus:	115 VAC, 6 amp, 1 phase, 60 Hz., 2-wire with ground 6' (1.8m) electric cord set furnished.
Both units:	Each unit requires a dedicated 15 amp. circuit.

### GAS SUPPLY:

	BC-14G	Zephaire G Plus
<b>Connection:</b>	3/4" NPT	3/4" IPS
<b>Inlet Pressure:</b>		
Natural	7.0" W.C.	7.0" W.C. minimum 10.5" W.C. maximum
Propane	14.0" W.C.	10.5" W.C. minimum 13.0" W.C. maximum

### Manifold Pressure:

Natural	N/A	3.5 W.C.
Propane	N/A	10.0 W.C.
<b>Maximum Input:</b>	115,000 BTU/hr	60,000 BTU/hr

### WATER SUPPLY (BC-14G only):

Minimum Water Quality - not to exceed 30 parts per million of dissolved solids. PH should be 7.0 or higher.  
40(min)-50(max) PSI 122°F (50°C) avg. drain temperature  
2" drain connection 3/4" hose cold water (Hot or filtered water optional, order part #R9603)

### SHIPPING INFORMATION:

#### Approx. Weight:

BC-14G	650 lbs. (295 kg)
Zephaire G Plus	640 lbs. (290 kg)

#### Crate sizes (per section):

BC-14G	53" H x 45" W x 42" D (1346.2 x 1143 x 1066.8mm)
Zephaire G Plus	37-1/2" (952mm) x 43-1/2" (1105mm) x 52" (1321mm)

**NOTE:** The company reserves the right to make substitutions of components without prior notice

### BLODGETT COMBI

www.blodgett.com

44 Lakeside Avenue, Burlington, VT 05401  
Phone: (802) 658-6600 • Fax: (802) 864-0183