



MODEL AC-500
Vertical Fired Gas Convection Oven
with Extra Capacity



Project _____

Item No. _____

Quantity _____

AC-500

Standard depth, extra height baking compartment - accepts up to eight 18" x 26" standard full-size baking pans in front-to-back positions. All data is shown per oven section, unless otherwise indicated.

EXTERIOR CONSTRUCTION

- Full angle iron frame
- Stainless steel exterior
- Stainless steel door with glass and 180° range of motion
- Chrome plated single stage door latch
- Modular slide out front control panel
- Solid mineral fiber insulation at top, back, sides and bottom

INTERIOR CONSTRUCTION

- Eight chrome-plated racks, seventeen rack positions with a minimum of 1-5/8" (41mm) spacing
- Double-sided porcelainized baking compartment liner (14 gauge)
- Induced back draft blower wheel
- Interior lights

OPERATION

- Vertical fired gas system with burners in side compartment
- Pilot ignition control system
- Four removable in-shot burners
- Pressure regulator and manual gas service cut-off valve located in front control area
- Solid state thermostat with temperature control range of 200°F (93°C) to 500°F (260°C)
- Two speed fan motor
- 3/4 horsepower blower motor with automatic thermal overload protection
- Control area cooling fan
- Two motor compartment cooling fans

STANDARD FEATURES

- Solid state manual control with separate dials to control thermostat and timer
- One year parts and labor oven warranty*
- Three year limited door warranty*

* For all international markets, contact your local distributor.

OPTIONS AND ACCESSORIES

(AT ADDITIONAL CHARGE)

- **Legs/casters:**
 - 6" (152mm) stainless steel legs
 - 25" (635mm) stainless steel legs
 - 25" (635mm) stainless steel legs with 6" casters (adjustable)
 - Low profile adjustable casters (for double unit)
- **Venting:**
 - Draft diverter
 - Draft hood
- Gas hose with quick disconnect and restraining device:
 - 48" (1219mm) hose
 - 36" (914mm) hose
- CH-Pro3 - Programmable solid state digital control with LED display, cook and hold, Pulse Plus®, 3 program product keys
- Stainless steel stand with rack guides
- Extra oven racks
- Gas manifold (for double sections)
- Extended warranty
- Flue connector

OPTIONS AND ACCESSORIES

(AT NO CHARGE)

- Solid stainless steel door



BLODGETT OVEN COMPANY

www.blodgett.com

44 Lakeside Avenue, Burlington, VT 05401

Phone: (802) 658-6600 • Fax: (802) 864-0183



MODEL AC-500

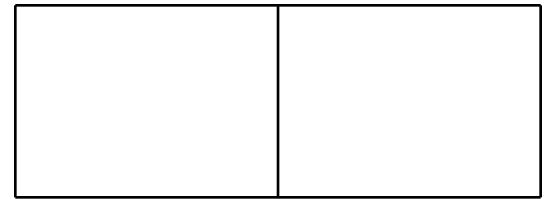

APPROVAL/STAMP

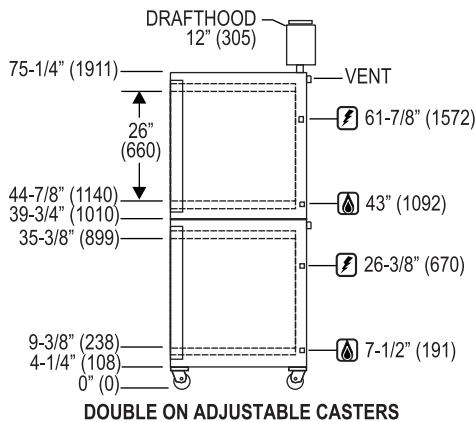
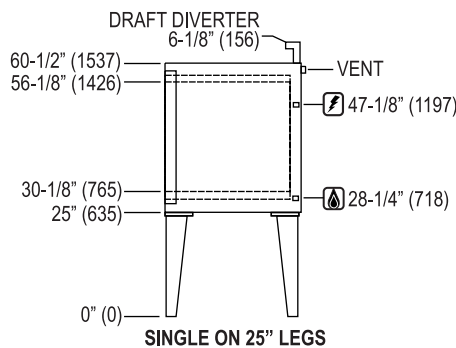
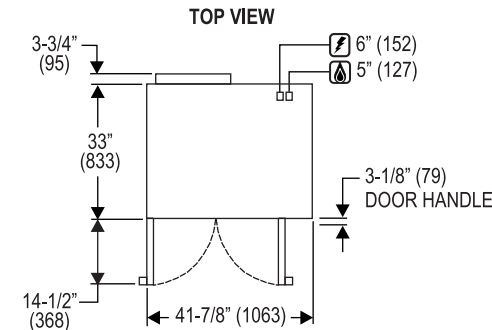

Dimensions are in inches (mm)

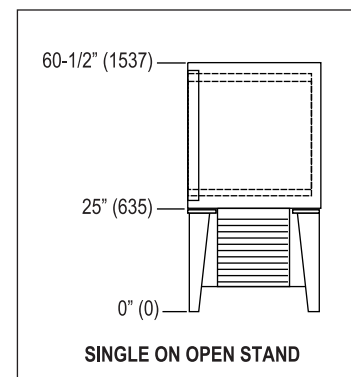

SHORT FORM SPECIFICATIONS

Provide Blodgett full-size convection oven model AC-500, (single/double) compartment. Each compartment shall have porcelainized liner and shall accept eight 18" x 26" standard full-size bake pans. Door shall be stainless steel with window, 180° range of motion. Unit shall be gas heated with pilot ignition control system and shall cook by means of a vertical fired gas system. Air in baking chamber distributed by induced back draft blower wheel powered by a two-speed, 3/4 HP motor with thermal overload protection. Each chamber shall be fitted with eight chrome-plated removable racks and seventeen available rack positions. Control panel shall be recessed with Cook/Cool Down mode selector, solid state (manual/digital) infinite thermostat (200- 500° F), and 60-minute timer. Provide options and accessories as indicated.

DIMENSIONS:

- Floor space** 41-11/16" (1059mm) wide x 33" (838mm) long
- Product clearance** 2" (51mm) from rear and left side and 0" (0mm) from right side.
- Interior** 27" (686mm) wide x 29-1/4" (743mm) high x 28-7/8" (733mm) deep

If oven is on adjustable casters add to all height dimensions: 1-3/4" (44.5mm)

GAS SUPPLY:

- 3/4" IPS connection at rear of oven
- Manifold Pressure:
 - Natural – 3.5" W.C.
 - Propane – 10" W.C.
- Inlet Pressure:
 - Natural – 4.5" W.C. min. – 11" W.C. max.
 - Propane – 10.5" W.C. min. – 13.0" W.C. max.

MAXIMUM INPUT:

- AC-500 Single 70,000 BTU/hr (20.5 Kw)
- AC-500 Double 140,000 BTU/hr (41 Kw)

NOTE: The company reserves the right to make substitutions of components without prior notice

POWER SUPPLY:

- 3-wire, 13 Amp, 120 VAC, 1 phase, 60 Hz.
- 3/4 H.P., 2 speed motor, 1140 and 1725 RPM
- 6' (1.8m) electric cord set furnished on 120 VAC ovens only.
- Each unit requires a dedicated 20 amp. circuit.

MINIMUM ENTRY CLEARANCE:

- Uncrated 33-3/4" (857mm)
- Crated 39" (990mm)

COMBUSTIBLE WALL CLEARANCE:

- Right side 0" (0mm)
- Rear and left side 2" (51mm)

SHIPPING INFORMATION:

- Approx. Weight:** Crated
- Single 600 lbs. (272 kg)
- Double 1200 lbs. (544 kg)

Crate sizes:

53" (1346mm) x 39" (991mm) x 41" (1041mm)

BLODGETT OVEN COMPANY

www.blodgett.com

44 Lakeside Avenue, Burlington, VT 05401 • Phone: (802) 658-6600 • Fax: (802) 864-0183