



Project \_\_\_\_\_

Item No. \_\_\_\_\_

Quantity \_\_\_\_\_

# MODEL DFG-100 Full-Size Dual Flow Gas Convection Oven



Standard depth baking compartment - accepts five 18" x 26" standard full-size baking pans in left-to-right positions.

All data is shown per oven section, unless otherwise indicated.

Refer to operator manual specification chart for listed model names.

### EXTERIOR CONSTRUCTION

- Full angle-iron frame
- Stainless steel front, top, and sides
- Dual pane thermal glass windows encased in stainless steel door frames
- Porcelain door handle with simultaneous door operation
- Triple-mounted pressure lock door design with turnbuckle assembly
- Modular slide out front control panel for easy cleaning
- Solid mineral fiber insulation at top, back, sides and bottom

### INTERIOR CONSTRUCTION

- Double-sided porcelainized baking compartment liner (14 gauge)
- Aluminized steel combustion chamber
- Dual inlet blower wheel
- Five chrome-plated racks, eleven rack positions with a minimum of 1-5/8" (41mm) spacing
- Interior lights

### OPERATION

- Dual Flow Gas system combines direct and indirect heat
- Electronic spark ignition control system
- Removable dual tube burners
- Pressure regulator
- Manual gas service cut-off switch located on the front of the control panel
- Air mixers with adjustable air shutters
- Solid state thermostat with temperature control range of 200°F (93°C) to 500°F (260°C)
- Two speed fan motor (single speed in CE model)
- 1/3 horsepower blower motor with automatic thermal overload protection
- Control area cooling fan
- Two 50 watt commercial bake oven lamps

### STANDARD FEATURES

- Solid state manual control with separate dials to control thermostat and timer
- 25" (635mm) adjustable stainless steel legs (for single units)
- 6" (152mm) adjustable stainless steel legs (for double sections)
- Draft diverter or draft hood for venting (select one)
- Two year oven parts and one year labor warranty\*
- Five year limited oven door warranty\*

\* For all international markets, contact your local distributor.



### OPTIONS AND ACCESSORIES

(AT ADDITIONAL CHARGE)

#### ■ Legs/casters/stands:

- 6" (152mm) seismic legs
- 6" (152mm) casters
- 4-1/4" (108mm) low profile casters (double only)
- 25" (635mm) stainless steel open stand with rack guides

#### ■ Gas hose with quick disconnect and restraining device:

- 48" (1219mm) hose
- 36" (914mm) hose

- Solid state digital control with LED display, cook and hold, and Pulse Plus®
- Stainless steel oven liner
- Extra oven racks
- Stainless steel solid back panel
- Gas manifold (for double sections)
- Prison package (includes security control panel and stainless steel back)
- Security control panel
- Flue connector

### OPTIONS AND ACCESSORIES

(AT NO CHARGE)

- Solid stainless steel doors

### BLODGETT OVEN COMPANY

www.blodgett.com

44 Lakeside Avenue, Burlington, VT 05401

Toll Free: (800) 331-5842 • Phone: (802) 860-3700 • Fax: (802) 864-0183



# MODEL DFG-100



APPROVAL/STAMP

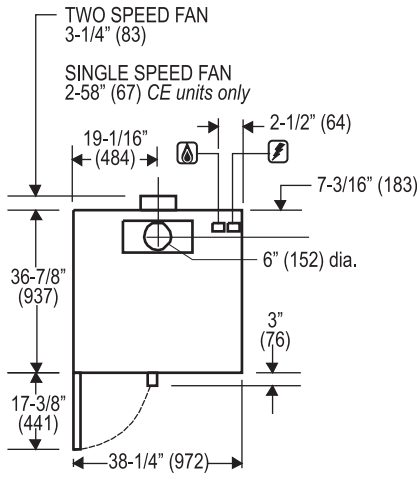

TOP VIEW

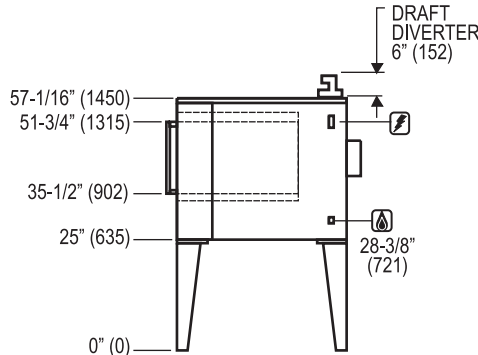

SINGLE

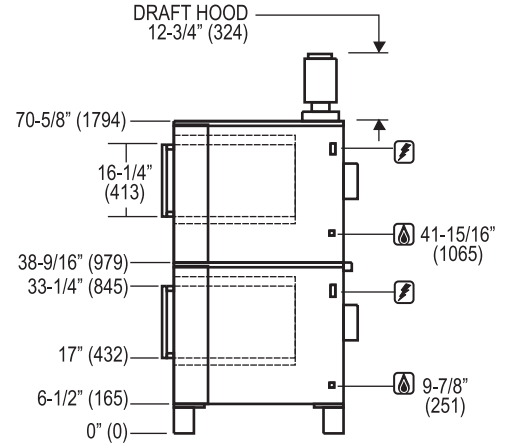

DOUBLE

Dimensions are in inches (mm)

### SHORT FORM SPECIFICATIONS

Provide Blodgett full-size convection oven model DFG-100, (single/double) compartment. Each compartment shall have (porcelainized/stainless) steel liner and shall accept five 18" x 26" standard full-size bake pans. Stainless steel front, top and sides. Doors shall be (solid stainless steel/ have dual pane thermal glass windows) with single porcelain handle and simultaneous operation. Unit shall be gas heated with electronic spark ignition and shall cook by means of a dual-flow system combining direct and indirect heat with a gas shutoff switch on the front of the control panel. Air in baking chamber distributed by dual inlet blower wheel powered by a two-speed (single speed for CE model), 1/3 HP motor with thermal overload protection. Each chamber shall be fitted with two commercial lamps and five chrome-plated removable racks. Control panel shall be recessed with Cook/Cool Down mode selector, solid state (manual/digital) infinite thermostat (200- 500°F), and 60-minute timer. Provide options and accessories as indicated.

### DIMENSIONS:

- Floor space** 38-1/4" (972mm) W x 36-7/8" (937mm) D
- Product clearance**
- Oven Back 0" from combustible and non-combustible construction.
- Oven Sides 2" from combustible and non-combustible construction.
- Interior** 29" (737mm) W x 20" (508mm) H x 24-1/4" (616mm) D
- If oven is on casters add to all height dimensions:**
- Single 4-1/2" (114mm)
- Double 2-1/4" (57mm)

### GAS SUPPLY:

- 3/4" NPT
- Manifold Pressure:
- Natural – 3.5" W.C. • Propane – 10" W.C.
- Inlet Pressure:
- Natural – 7.0" W.C. min. – 10.5" W.C. max.
- Propane – 11.0" W.C. min. – 13.0" W.C. max.

### MAXIMUM INPUT:

- Single 55,000 BTU/hr (16.2 Kw)
- Double 110,000 BTU/hr (32.4 Kw)

### POWER SUPPLY:

- 115 VAC, 1 phase, 6 Amp, 60 Hz., 2-wire with ground, 1/3 H.P., 2 speed motor, 1140 and 1725 RPM
- 230V CE model, 1 phase, 3 Amp, 50 Hz., 2-wire with ground, 1/3 H.P., 1 speed motor, 1425 RPM
- 6' (1.8m) electric cord set furnished on 115 VAC ovens only.

### MINIMUM ENTRY CLEARANCE:

- Uncrated 32-1/16" (814mm)
- Crated 37-1/2" (953mm)

### SHIPPING INFORMATION:

- Approx. Weight:**
- Single 590 lbs. (268 kg)
- Double 1095 lbs. (497 kg)
- Crate sizes:**
- 37-1/2" (952mm) x 43-1/2" (1105mm) x 51-3/4" (1315mm)

**NOTE:** The company reserves the right to make substitutions of components without prior notice

### BLODGETT OVEN COMPANY

www.blodgett.com

44 Lakeside Avenue, Burlington, VT 05401 Toll Free: (800) 331-5842 • Phone: (802) 860-3700 • Fax: (802) 864-0183