



MODEL KCO-25E

Kiosk Convection Oven

KCO-25E

Project _____

Item No. _____

Quantity _____

14-3/4" deep compartment - accepts three 9" x 13" quarter size baking pans in front-to-back position.

All data is shown per oven section, unless otherwise indicated.



EXTERIOR CONSTRUCTION

- Stainless steel front, top, sides and back
- Aluminized steel bottom
- Unibody construction
- Front loading solid stainless steel door
- Field reversible door with handle
- High temperature insulation at sides, bottom, back and top

INTERIOR CONSTRUCTION

- Stainless steel interior and baffle
- 15-3/4" (400mm) W x 13" (330mm) H x 14-1/2" (375mm) D.
- 3 Chrome plated steel wire racks, 15-5/8" (397mm) x 11" (279mm) with 3-3/8" (86mm) spacing

OPERATION

- Heat transferred through forced air convection
- Baking compartment vented through rear of oven
- Displays minutes and seconds with buzzer
- Blower motor (1/6 HP minimum) with thermal overload protection

STANDARD FEATURES

- Solid state digital display timer with 6-program time and temperature settings
- 4" (102mm) black legs
- Oven ready light
- Modular control area which can slide forward or be removed for servicing
- 20 Amp single phase power cord with NEMA L6-20 plug assembled at the factory
- One year limited parts & labor warranty

* For all international markets, contact your local distributor.

OPTIONS AND ACCESSORIES

(AT ADDITIONAL CHARGE)

- Wire racks



BLODGETT OVEN COMPANY

www.blodgett.com

44 Lakeside Avenue, Burlington, VT 05401 • Phone: (802) 658-6600 • Fax: (802) 864-0183



MODEL KCO-25E



APPROVAL/STAMP

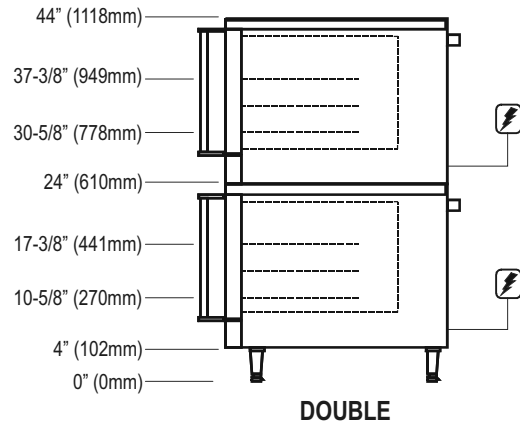
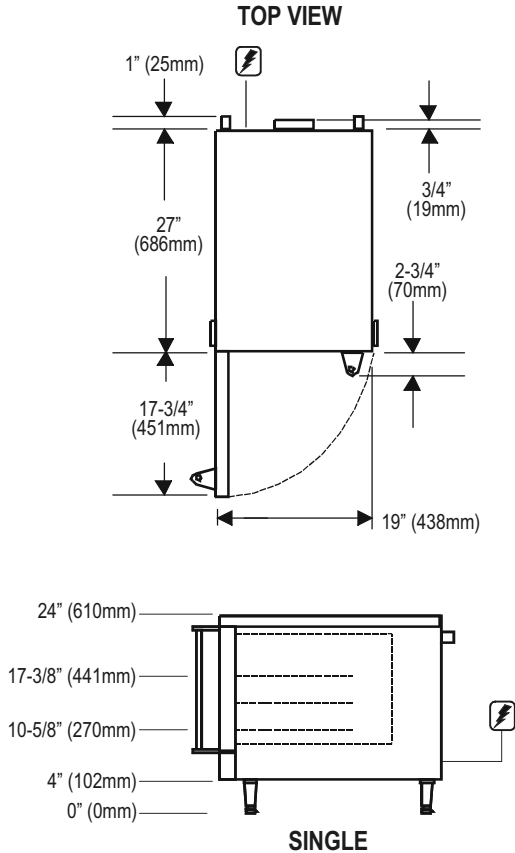

DIMENSIONS:

Floor space 19" (483mm) W x 28" (711mm) D
Installation clearance 0" from combustible and non-combustible construction
Interior 15-3/4" (400mm) W x 13" (330mm) H x 14-1/2" (375mm) D

MAXIMUM INPUT:

Single 3 KWH per section

POWER SUPPLY:

Domestic:

208 VAC 60Hz 1 phase 3.0KWH 15 Amperes 1/6 H.P. 1 speed motor 1725 RPM
 240 VAC 60/50Hz 1 phase 3.0KWH 13 Amperes 1/6 H.P. 1 speed motor 1725 RPM
 Domestic models supplied with power cord and NEMA L6-20 plug for use with NEMA L6-20R receptacle

Export:

230 VAC 60/50Hz 1 phase 3.0KWH 13 Amperes 1/6 H.P. 1 speed motor 1725 RPM
 220 VAC 60/50Hz 1 phase 3.0KWH 14 Amperes 1/6 H.P. 1 speed motor 1725 RPM
 200 VAC 60/50Hz 1 phase 3.0KWH 15 Amperes 1/6 H.P. 1 speed motor 1725 RPM

NOTE: The company reserves the right to make substitutions of components without prior notice

MINIMUM ENTRY CLEARANCE:

Uncrated 20" (508mm)
 Crated 24-3/8" (619mm)

SHIPPING INFORMATION:

Approx. Weight:

Single 170 lbs. (77kg)

Crate sizes:

24-3/8" (619mm) x 35-5/8" (905mm) x 25-1/2" (648mm)

BLODGETT OVEN COMPANY

www.blodgett.com

44 Lakeside Avenue, Burlington, VT 05401 • Phone: (802) 658-6600 • Fax: (802) 864-0183