



# MODEL ZEPHAIRE-E PLUS

Full-size Electric Convection Oven

ZEPHAIRE-E PLUS



Project \_\_\_\_\_

Item No. \_\_\_\_\_

Quantity \_\_\_\_\_

Extra depth baking compartment- accepts five 18" x 26" standard full-size baking pans in left-to-right or front-to-back positions.

All data is shown per oven section, unless otherwise indicated.

Refer to operator manual specification chart for listed model name.

### EXTERIOR CONSTRUCTION

- Full angle-iron frame
- Stainless steel front, top, and sides
- Dual pane thermal glass windows encased in stainless steel door frames
- Porcelain door handle with simultaneous door operation
- Triple-mounted pressure lock door design with turnbuckle assembly
- Removable front control panel
- Solid mineral fiber insulation at top, back, sides and bottom

### INTERIOR CONSTRUCTION

- Double-sided porcelainized baking compartment liner (14 gauge)
- Aluminized blower wheel
- Five chrome-plated racks, eleven rack positions with a minimum of 1-5/8" (41mm) spacing

### OPERATION

- Three tubular heaters
- Solid state thermostat with temperature control range of 200°F (93°C) to 500°F (260°C)
- Two speed fan motor
- 1/3 horsepower blower motor with automatic thermal overload protection
- Control area cooling fan
- Two 50 watt commercial bake oven lamps

### STANDARD FEATURES

- Solid state manual controls with separate dials for thermostat and timer
- 25" (635mm) adjustable stainless steel legs (for single units)
- 6" (152mm) adjustable stainless steel legs (for double sections)
- 60 minute electric timer with buzzer
- One year parts and labor warranty\*
- Three year limited oven door warranty\*

\* For all international markets, contact your local distributor.

### OPTIONS AND ACCESSORIES

(AT ADDITIONAL CHARGE)

- **Legs/casters/stands:**
  - 6" (152mm) seismic legs
  - 6" (152mm) casters
  - 4" (102mm) low profile casters (double only)
  - 25" (635mm) stainless steel open stand with rack guides
- Extra oven racks
- Vent connector
- 480 VAC, 3 phase
- Extended warranty



### BLODGETT OVEN COMPANY

www.blodgett.com

44 Lakeside Avenue, Burlington, VT 05401

Toll Free: (800) 331-5842 • Phone: (802) 860-3700 • Fax: (802) 864-0183



# MODEL ZEPHAIRE-E PLUS



APPROVAL/STAMP

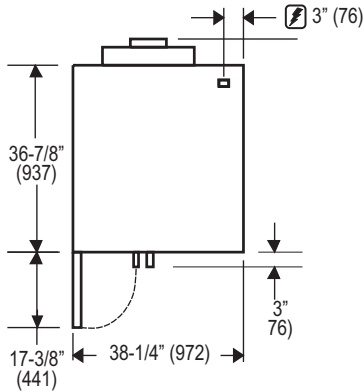

TOP VIEW

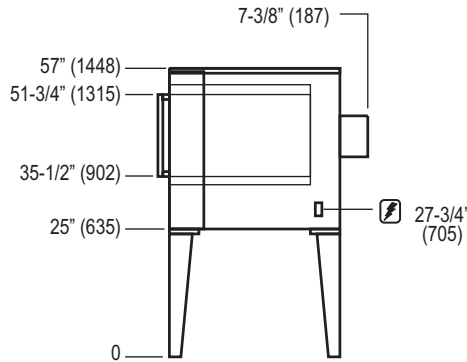

SINGLE

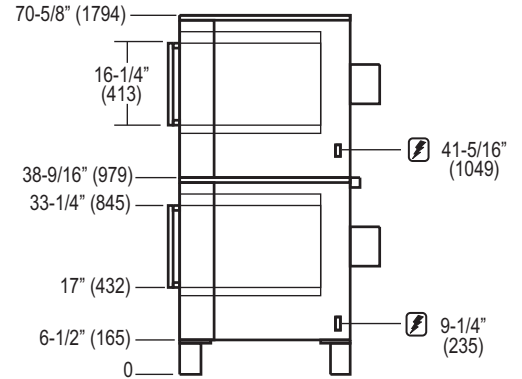

DOUBLE

Dimensions are in inches (mm)

### SHORT FORM SPECIFICATIONS

Provide Blodgett full-size convection oven model ZEPHAIRE-E PLUS, (single/double) compartment. Each compartment shall have porcelainized steel liner and shall accept five 18" x 26" standard full-size bake pans in left-to-right or front-to-back positions. Doors shall have dual pane thermal glass windows with single porcelain handle and simultaneous operation. Unit shall be electrically heated with three tubular heaters. Air in baking chamber distributed by single inlet blower wheel powered by a two-speed, 1/3 HP motor with thermal overload protection. Each chamber shall be fitted with five chrome-plated removable racks. Control panel shall be recessed with Cook/Cool Down mode selector, solid state manual infinite thermostat (200 - 500°F), and 60-minute timer. Provide options and accessories as indicated.

### DIMENSIONS:

- Floor space:** 38-1/4" (972mm) W x 36-7/8" (936mm) L
- Product clearance:** 1/2" from combustible and non-combustible construction.
- Interior:** 29" (737mm) W x 20" (508mm) H x 28-1/4" (718mm) D
- If oven is on casters add to all height dimensions:**
  - Single 4-1/2" (114mm)
  - Double 2-1/4" (57mm)

### POWER SUPPLY:

- 208 VAC 60 Hz. 1 phase 11KW 51/0/51 Amperes,
- 208 VAC 60 Hz. 3 phase 11KW 31/29/29 Amperes,
- 220/240 VAC 60 Hz. 1 phase 11KW 44/0/44 Amperes,
- 220/240 VAC 60 Hz. 3 phase 11KW 26/24/24 Amperes,
- 440 VAC 60 Hz. 3 phase 11KW 15/14/14 Amperes,
- 480 VAC 60 Hz. 3 phase 11KW 14/13/13 Amperes,
- 1/3 HP, 2 speed motor, 1140 & 1725 rpm (60 Hz)
- (50 Hz. ovens for 400/230, 380Y/220 VAC or 415Y/240 VAC (4 wire) 3 phase are available)

### MAXIMUM INPUT:

- Single 11KW
- Double 22Kw (11KW each section)

### MINIMUM ENTRY CLEARANCE:

- Uncrated 32-1/16" (814mm)
- Crated 37-1/2" (953mm)

### SHIPPING INFORMATION:

- Approx. Weight:**
  - Single: 545 lbs. (247 kg)
  - Double: 1060 lbs. (481 kg)
- Crate sizes:** 37-1/2" (952mm) x 43-1/2" (1105mm) x 51-3/4" (1315mm)

**NOTE:** The company reserves the right to make substitutions of components without prior notice

### BLODGETT OVEN COMPANY

www.blodgett.com

44 Lakeside Avenue, Burlington, VT 05401 Toll Free: (800) 331-5842 • Phone: (802) 860-3700 • Fax: (802) 864-0183