



S1820E

MODEL S1820E Electric Conveyor Oven



Project _____

Item No. _____

Quantity _____

All data is shown per oven section, unless otherwise indicated.
Blodgett electric conveyor oven with 18" (457mm) wide belt and 20" (508mm) baking zone length. Single, double, or triple stack models are available.

EXTERIOR CONSTRUCTION

- Stainless steel front, sides, top and interior
- Easy serviceable access to all components
- Exterior top and front surfaces are cool to the touch
- Fully insulated on bottom, top, front and rear.
- Finished back

INTERIOR CONSTRUCTION

- Stainless steel outer (finger) plates
- 18" (457mm) wide stainless steel wire mesh conveyor belt
- 20" (508mm) long bake chamber
- Two single inlet blowers behind the heat source for forced air circulation, supplying top and bottom air flow
- Standard or Customer specific finger set that allows control of 6 heat zones inside the bake chamber. Finger set consists of manifolds, inner plates, outer plates and blank plate(s)

OPTIONS AND ACCESSORIES

(AT ADDITIONAL CHARGE)

- Stainless steel stand with casters, two with brakes (Cart size is 42" (1066.8mm) wide by 32" 812.8mm deep)
 - 25" (635) tall with stainless steel undershelf for single and double stack
 - 12" (305) tall for triple stack
- One year additional extended warranty*

STANDARD FEATURES

- Energy efficient heating system that improves cooking results and saves energy
- Solid state controls
- Temperature controller's built in auto tune feature improves overall conveyor oven performance
- Microprocessor-controlled conveyor speed with motor feedback
- Stackable to three high
- Removable conveyor frame and belt assembly
- 4" (102mm) legs for single and double stack units
- Removable 6" (152mm) and 12" (305mm) shelf extension
- Adjustable conveyor belt tension
- Field reversible conveyor belt direction
- Factory attached 6' cord with NEMA 6-50P plug for 208V and 240V (cord for 380V and 480V not provided)
- One year parts and labor warranty
- Start Up by our Authorized Service Provider to activate the warranty (USA and Canada only)*

OPERATION

- Solid state digital controls to display set point and actual bake chamber temperature(s) as well as bake time.
- Maximum Temperature is 550 degrees F (one degree increment)
- 1 – 10 minute bake time (one second increment)
- Two blower motors with thermal overload protectors
- Product clearance 3 1/2" (889mm)
- Heat transferred through forced directed hot air impingement
- Open vented baking chamber
- Watlow Firebar resistance heating element
- One blower cooling fan
- Easy to clean – no tools required



* For all international markets, contact your local distributor.

BLODGETT OVEN COMPANY

www.blodgett.com

1400 Toastmaster Drive, Elgin, IL USA 60120 • Phone: (847) 741-3300 • Fax: (847) 741-0015



MODEL S1820E



APPROVAL/STAMP

DIMENSIONS ARE IN INCHES (MM)

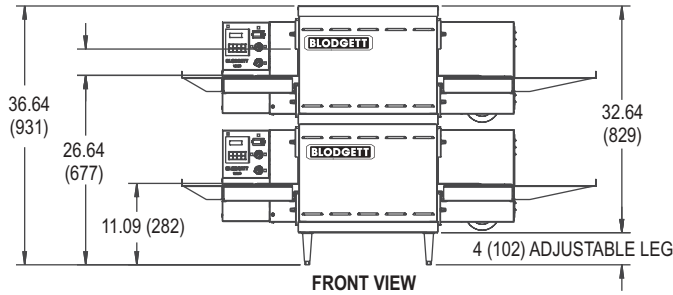

FRONT VIEW

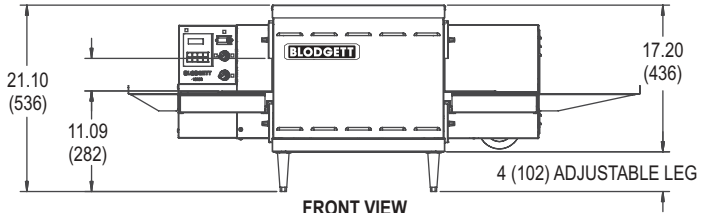

FRONT VIEW

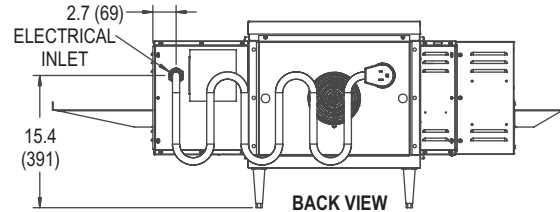

BACK VIEW

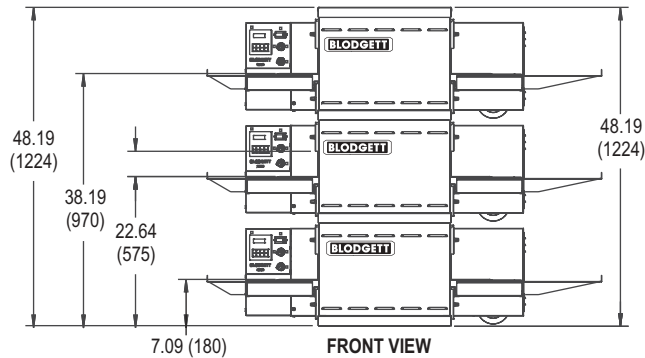

FRONT VIEW

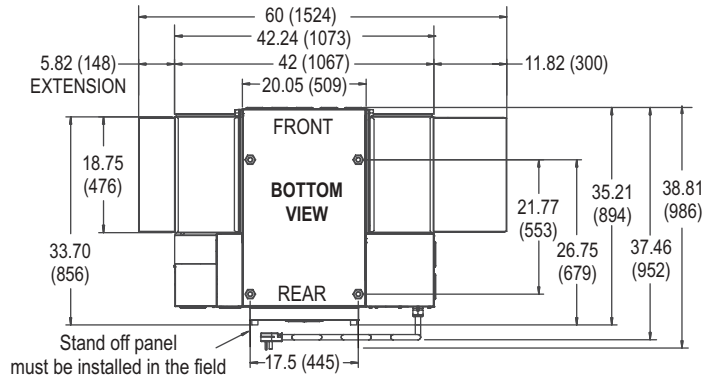

FRONT

BOTTOM VIEW

REAR

SHORT FORM SPECIFICATIONS

Provide Blodgett model S1820E conveyor oven. Unit shall be electrically heated and shall cook by means of forced, heated air. Unit shall be (single/double/triple) deck supported by (specify stand type from options list). Each deck shall be fully independent, of stainless steel construction, and fully insulated on bottom, top, front and rear. Provide with electrically heated baking compartment with two blowers to evenly distribute heat across baking zone. Conveyor belt shall be 18" (457mm) wide and constructed of stainless steel wire mesh; baking zone length shall be 20" (510mm). Side mounted control panel shall be solid state with 550°F (288°C) maximum thermostat and digital display of adjustable belt speed. Provide options and accessories as indicated.

DIMENSIONS:

Floor space	38.81" (986mm) W x 42" (1067mm) L
Product clearance	3-1/2" (89mm)
Recommended minimum wall clearance	0" (0mm) left side, right side and rear
Belt width	18" (455mm)
Baking zone length	20" (510mm)

POWER SUPPLY: (must have dedicated ground)

V.A.C.	Hz	Phase	KW	Amps
DOMESTIC				
208	50/60	1	8.3	39.9
230-240	50/60	1	7.6-8.3	33-34.6
480	50/60	1	8.3	17.3
CE MODEL				
230/240	50/60	1	7.6-8.3	33-34.6
230/400	50/60	1	8.3	23.8
380	50/60	3	8.3	21.8 (L1, L2, L3 & N)

MAXIMUM INPUT:

Single	8.3 KW
Double	16.6 KW
Triple	24.9 KW

MINIMUM ENTRY CLEARANCE:

Uncrated 18" (457mm)

SHIPPING INFORMATION:

Approx. Weight:

Single:	325 lbs. (147.2 kg)
Double:	650 lbs. (294.48 kg)
Triple:	975 lbs. (442.25 kg)

Crate sizes:

46" L x 39" W x 29" H (1168 x 991 x 737 mm)

NOTE: Blodgett Oven, in accord with its policy to continually improve its products, reserves the right to change materials or specifications without notice. Such revisions do not entitle the buyer to corresponding changes, improvements, additions, or replacements for previously purchased equipment.

BLODGETT OVEN COMPANY

www.blodgett.com • 1400 Toastmaster Drive, Elgin, IL USA 60120 • Phone: (847) 741-3300 • Fax: (847) 741-0015