

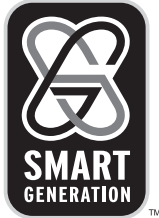

# MODEL SG2136E/G

Electric/Gas Conveyor Oven



SG2136E/G

Project \_\_\_\_\_

Item No. \_\_\_\_\_

Quantity \_\_\_\_\_

Blodgett conveyor oven with 21" (533mm) wide belt and 36" (915mm) baking zone length. Single, double or triple stack models. Base units available for stacking with existing oven.

All data is shown per oven section, unless otherwise indicated.

### EXTERIOR CONSTRUCTION

- Stainless steel front, top and sides
- Aluminized steel back and bottom
- Full drop down removable front door
- Front pull down door for sandwiches or other product
- Foil faced ceramic fiber insulation

### INTERIOR CONSTRUCTION

- Aluminized steel nozzles and air plates
- Adjustable aluminized steel air flow plate at top
- 21" (534mm) stainless steel wire mesh conveyor belt
- Two single inlet blowers above the combustion/element area for air circulation

### OPERATION

- Heat transferred through forced directed hot air impingement
- Open vented baking compartment
- Electronic spark ignition control system (gas model)
- Gas power type burner has mixer with adjustable shutter and sight window (gas model)
- Internal gas pressure regulator (gas model)
- Tubular resistance elements (electric model)
- Integral or remote microprocessor based controls with solid state 600°F (315°C) maximum thermostat and belt speed control with backlit LCD display
- Two circulation blower motors with thermal overload protectors
- 1-30 minute bake time

### STANDARD FEATURES

- Front mounted digital control options: *(must specify)*
  - manual
  - menu (4 program keys, stores time/temp settings)
- Self diagnostics, monitors and alerts operator of warning or fault conditions
- Belt direction: *(must specify)*
  - left to right
  - right to left
- Product stop
- Oven start-up\*
- One year parts & labor warranty\*

\* For all international markets, contact your local distributor.

### OPTIONS AND ACCESSORIES

(AT ADDITIONAL CHARGE)

- Legs/cradles
  - 23-1/4" (591mm) black legs with casters
  - 17-1/4" (438mm) black legs with casters
  - Triple stack plate with casters
- Shelf extensions
  - 6" (152mm)
  - 12" (305mm)
- Remote control
  - 10' (3.0M) cable
  - 50' (15.24M) cable
- Flexible gas hose with quick disconnect and restraining device
  - 36" (914mm)
  - 48" (1219mm)

Note: Two 48" (1219mm) and one 36" (914mm) hose on triple model

- Stainless steel interior, nozzles and air plates
- Cord set, locking plug and receptacle(domestic gas ovens only)
- One year additional extended warranty\*



BLODGETT OVEN COMPANY

www.blodgett.com

1400 Toastmaster Drive, Elgin, IL USA 60120 • Phone: (847) 741-3300 • Fax: (847) 741-0015



# MODEL SG2136E/G

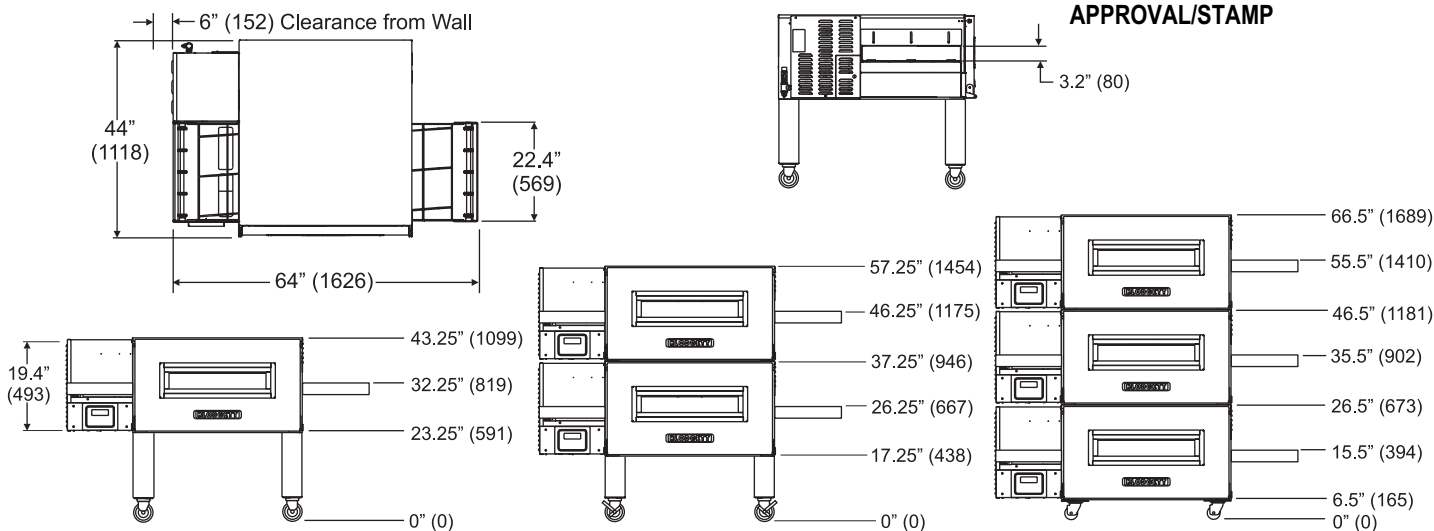
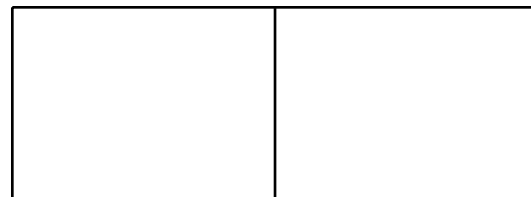

### SHORT FORM SPECIFICATIONS

Provide Blodgett conveyor model SG2136(G/E) conveyor oven. Unit shall be (gas fired/electrically heated) and shall cook by means of forced, heated air. Unit shall be (single/double/triple) deck supported by (specify leg height or cradle from options list). Each deck shall be fully independent, of stainless steel construction, and fully insulated on all sides. Provide with (electronic spark ignition gas fired/electrically heated) baking compartment with two blowers to evenly distribute heat across baking zone. Conveyor belts shall be single - 21" (533mm) belt constructed of stainless steel wire mesh; baking zone length shall be 36" (915mm). Unit shall be provided with drop down full front door. (Front mounted/remote) control panel shall be solid state with 600°F (315°C) maximum thermostat and LCD display of 1-30 minutes adjustable belt speed. Provide start-up inspection service by a factory authorized service agent. Provide options and accessories as indicated.

### DIMENSIONS:

<b>Floor space</b>	44" (1118mm) W x 64" (1625mm) L
<b>Product clearance</b>	3.2" (80mm)
<b>Wall clearance</b>	
All models	0" (0mm) right side and rear
	6" (152mm) left/control box side
<b>Belt width</b>	21" (533mm)
<b>Baking zone length</b>	36" (915mm)

<b>MAXIMUM INPUT:</b>	<b>SG2136G</b>	<b>SG2136E</b>
Single	60,000 BTU/hr (63.3 MJ/Hr) (17.6 KW)	15kW
Double	120,000 BTU/hr (126.6 MJ/Hr) (35.2 KW)	30kW
Triple	180,000 BTU/hr (189.9 MJ/Hr) (52.7 KW)	45kW

<b>GAS SUPPLY:</b>	<b>3/4" NPT</b>	
<b>Gas Pressure</b>	<b>Natural Gas</b>	<b>Propane Gas</b>
Minimum	4.5" W.C. (11.2 mbar)	11.0" W.C. (27.4 mbar)
Maximum	10.5" W.C. (26.1 mbar)	13" W.C. (32.3 mbar)

### MINIMUM ENTRY CLEARANCE:

Crated - 27" (686mm)      Uncrated - 20" (508mm)

### SHIPPING INFORMATION:

<b>Approx. Weight</b>	<b>Crated</b>	<b>Uncrated</b>
Single	600 lbs. (272 kg)	460 lbs. (209 kg)
Double	1200 lbs. (544 kg)	920 lbs. (418 kg)
Triple	1800 lbs. (816 kg)	1380 lbs. (627 kg)

\*Add: 37 lbs. (17kg) - triple casters; 70 lbs. (32kg) - 17-1/4" legs; 87 lbs. (39kg) - 23-1/4" legs

### Crate sizes

Domestic	52.8" (1341mm) H x 74" (1880mm) W x 27" (686mm) D
Export	53.8" (1367mm) H x 58" (1473mm) W x 30" (762mm) D

### POWER SUPPLY (must have dedicated ground)

<b>SG2136E</b>							
<b>V.A.C.</b>	<b>Hz</b>	<b>Phase</b>	<b>kW</b>	<b>Amperes</b>			
				<b>L1</b>	<b>L2</b>	<b>L3</b>	<b>L4</b>
<b>DOMESTIC</b>							
208	60	1	16	76	76	-	-
240	60	1	16	66	66	-	-
208	60	3	16	44	44	44	-
240	60	3	16	38	38	38	-
<b>INTERNATIONAL</b>							
220	50 or 60	1	16	73	73	-	-
240	50 or 60	1	16	66	66	-	-
220/380	50 or 60	3N	16	24	24	24	-
240/415	50 or 60	3N	16	23	23	23	-

### CE MODEL

230/400 50 3N 16 22 22 22 -  
 This oven contains a mercury relay. DO NOT put mercury relay in trash. Relay must be recycled or disposed of as hazardous waste.

### SG2136G

**DOMESTIC**  
 2-wire plus ground, 5 amp. 208-240 VAC, 1 phase, 60 Hz.

**INTERNATIONAL**  
 2-wire plus ground, 5 amp. 208-240 VAC, 1 phase, 50 or 60 Hz

**CE MODEL**  
 230VAC, 50 Hz, 5 amp., 2 wire plus ground

**NOTE:** The company reserves the right to make substitutions of components without prior notice.

### BLODGETT OVEN COMPANY

www.blodgett.com  
 1400 Toastmaster Drive, Elgin, IL USA 60120  
 Phone: (847) 741-3300 • Fax: (847) 741-0015