



MODEL 1405/1415 Countertop Electric Deck Oven



Model 1405 shown with manual controls

1405/1415 COUNTERTOP DECK

Project _____

Item No. _____

Quantity _____

Ovens consist of basic sections and are a complete and separate unit capable of operating alone or in combination. All data is shown per oven section, unless otherwise indicated.

EXTERIOR CONSTRUCTION

- Stainless steel front, top and sides
- Aluminized steel back and bottom
- Drop down type doors
- 1" high-temperature mineral fiber sheet insulation on top, back, sides and bottom

INTERIOR CONSTRUCTION

- 20" x 20" x 9" (508mm x 508mm x 229mm) oven compartment interior
- Aluminized steel baking compartment liner
- Cordierite oven deck
- Removable center heating element and shelf assembly
- No. 16 gauge aluminized steel heater shelf assemblies

OPERATION

- 3 tubular type heaters (208 or 240 VAC) 3750 total watts
- Thermostat actuated contactor heater control
- Model 1405 - Electromechanical thermostat with temperature control range of 200° to 600°F (93° to 316°C) and a 60 minute mechanical timer with buzzer.
- Model 1415 - Solid state digital display control with temperature range of 150° to 500°F (66° to 260°C) and a maximum 12 hour timer with audible alarm.

STANDARD FEATURES

- Fahrenheit dial 200° to 500°F
- Two year limited parts and labor warranty*

* For all international markets, contact your local distributor.

OPTIONS AND ACCESSORIES
(AT ADDITIONAL CHARGE)

- Stacking kit
- 4" legs with adjustable sanitary feet

OPTIONS AND ACCESSORIES
(AT NO ADDITIONAL CHARGE)

- 12 gauge formed aluminized steel deck
- Infinite control thermostat with timer (1405)
- Steel oven deck



BLODGETT OVEN COMPANY

www.blodgett.com

44 Lakeside Avenue, Burlington, VT 05401 • Phone: (802) 658-6600 • Fax: (802) 864-0183



MODEL 1405/1415



APPROVAL/STAMP

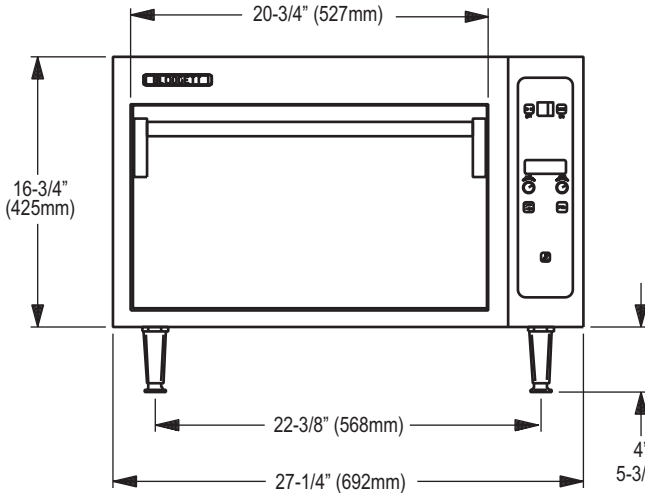

FRONT VIEW

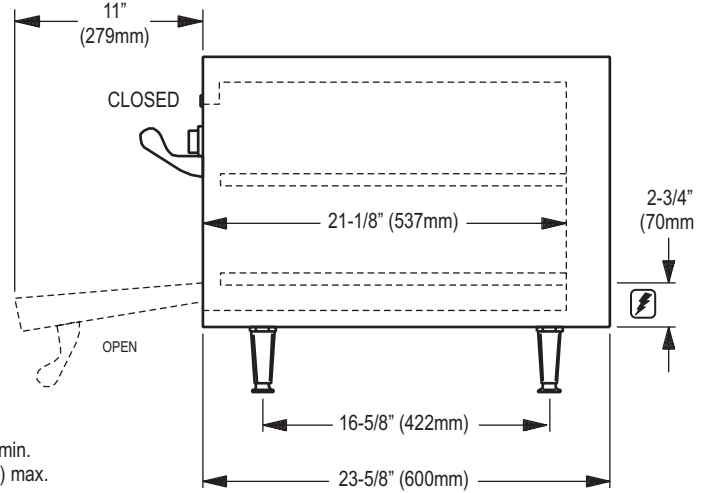

SIDE VIEW

DIMENSIONS:

	Single	Double
Number of sections:	1	2
Number of controls:	1	2
Number of compartments:	1	2
Size of compartments:	20" D x 20" H (508mm W x 508mm H)	
Clearance below oven:	4" (102mm) minimum	
Counter space:	27-3/8" x 23-11/16" (695mm x 602mm)	
Minimum entry clearance:	23" (548mm)	

POWER SUPPLY:

1400 Series (three heaters)

- 208 VAC, 60 Hz, 1 Phase, 3750 Watts, Line Amps 18
- 208 VAC, 60 Hz, 3 Phase, 3750 Watts, Line Amps 11-11-11
- 220-240 VAC, 60 Hz, 1 Phase, 3750 Watts, Line Amps 16
- 220-240 VAC, 60 Hz, 3 Phase, 3750 Watts, Line Amps 9-9-9
- 220-380 VAC, 50 Hz, 3 Phase, 3750 Watts, Line Amps 6-6-6
- 240-215 VAC, 50 Hz, 3 Phase, 3750 Watts, Line Amps 6-6-6
- 240 VAC, 50 Hz, 1 Phase, 3750 Watts, Line Amps 16
- 220 VAC, 50 Hz, 1 Phase, 3750 Watts, Line Amps 17

This oven contains a mercury relay. DO NOT put mercury relay in trash. Relay must be recycled or disposed of as hazardous waste.

NOTE: The company reserves the right to make substitutions of components without prior notice

MINIMUM ENTRY CLEARANCE:

Uncrated	17"
Crated	26"

SHIPPING INFORMATION:

Approx. Weight:	Crated	Uncrated
1405 Single:	215 lbs. (98 kg)	195 lbs. (88 kg)
1415 Single:	215 lbs. (98 kg)	195 lbs. (88 kg)
1405 Double:	430 lbs. (195 kg)	390 lbs. (177 kg)
1415 Double:	430 lbs. (195 kg)	390 lbs. (177 kg)
Crate size:	33" x 37" x 26" (838 mm x 940 mm x 661 mm)	

BLODGETT OVEN COMPANY

www.blodgett.com

44 Lakeside Avenue, Burlington, VT 05401 • Phone: (802) 658-6600 • Fax: (802) 864-0183