



951/966 - Double

MODEL 951/966 Deck Oven



Project _____
Item No. _____
Quantity _____

All ovens consist of basic sections and are a complete and separate unit capable of operating alone or in combination.
All data is shown per oven section, unless otherwise indicated.
Refer to operator manual specification chart for listed model name.

EXTERIOR CONSTRUCTION

- Full angle iron frame
- Stainless steel front, top, sides and back
- Counterbalanced doors with concealed hinges
- Heavy chrome plated tubular steel door handle
- 7" (178mm) stainless steel legs are adjustable for leveling
- Burner door opens easily for ignition, cleaning or adjustment, without removal of any fastenings
- Vitreous fiber insulation at top, back, sides, bottom and doors

INTERIOR CONSTRUCTION

- (1 – 951) 42" x 32" x 12" (1067mm x 813mm x 305mm)
- (1 – 966) 42" x 32" x 16-1/4" (1067mm x 813mm x 413mm) oven compartment interior
- Aluminized steel baking compartment liner
- Aluminized steel combustion chamber
- Steel deck supported by an angle iron frame
- 12 gauge (3.02mm) press-formed, reinforced and flanged aluminized steel deck

OPERATION

- Free-floating, easily removable duplex-tube burner
- Removable fixed orifices on main and pilot burner
- Main gas valve, temperature control valve and safety pilot valve fully within section body and are accessible through a covered and ventilated compartment in front.
- Air mixers with adjustable air shutters and locking device
- Snap throttle thermostat with temperature control range of 200°F (93°C) to 500°F (288°C)

STANDARD FEATURES

- Fahrenheit dial 200°F to 500°F
- Vent kit
- Large crown angle trim
- Double connector for stacking
- Steel oven deck
- Two year parts and one year labor warranty
- Five year limited oven door warranty*

* For all international markets, contact your local distributor.

OPTIONS AND ACCESSORIES
(AT ADDITIONAL CHARGE)

- Flexible gas hose with quick disconnect and restraining device:
 - 36" (914 mm)
 - 48" (1219mm)
- Ultra Rokite shelves, 1-1/2" (38.1mm) thick (pizza type shelf)
- Steam jets

OPTIONS AND ACCESSORIES
(AT NO ADDITIONAL CHARGE)

- FDTH 300° to 650° temperature thermostat
- Centigrade dial, 100°C to 300°C



BLODGETT OVEN COMPANY

www.blodgett.com

44 Lakeside Avenue, Burlington, VT 05401 • Phone: (802) 658-6600 • Fax: (802) 864-0183



MODEL 951/966



APPROVAL/STAMP

DIMENSIONS ARE IN INCHES (MM)

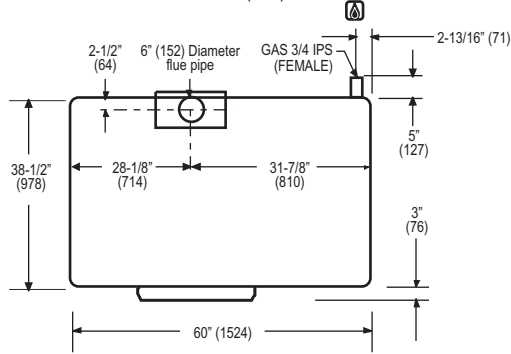

TOP VIEW

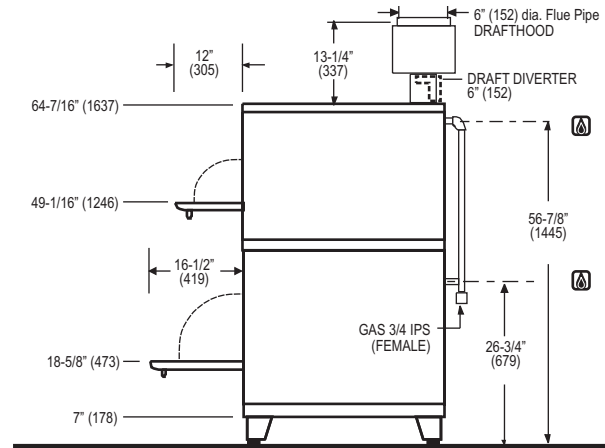

SHORT FORM SPECIFICATIONS

Provide Blodgett combination deck oven, model 951/966. Each unit shall be a combination of two independent ovens with single, manifolded gas connections and flues. Construction shall be welded stainless steel front, top, back and sides, and shall be fully insulated on all sides. Ovens shall be supported by adjustable legs. Doors shall be counterbalanced (no springs) with concealed hinges and chrome plated tubular steel handles. Separate burner door provided for ignition, cleaning and adjustment. The upper section baking compartment shall be 42" W x 12" H x 32" D; the lower section baking compartment shall be 42" W x 16-1/4" H x 32" D. Both shall be lined with aluminized steel, and decks shall be of 11 gauge press-formed, reinforced and flanged steel. Each section shall be gas heated by a free-floating, easily removable, duplex-type burner controlled by a liquid pressure thermostat with range of 200°F to 500° F. Provide with two year parts and one year labor warranty. Provide with options and accessories as indicated.

DIMENSIONS:

- Number of sections: 2
- Number of controls: 2
- Number of compartments: 2
- Size of compartment (1): 42" (1067mm) W x 12" (305mm) H x 32" (813mm) D
- (1): 42" (1067mm) W x 16-1/4" (413mm) H x 32" (813mm) D
- Area of each compartment: 9.34 sq. ft. (0.87m²)
- Total area of oven: 18.68sq. ft. (1.74m²)
- Clearance below oven: 6 (152mm)
- Floor space: 60" (1524mm) wide x 40" (1016mm) deep
- Product clearance: 6" from combustible and non-combustible construction

PAN CAPACITIES:

- 10" (254mm) pie tins: 24
- 18" x 26" (457mm x 660mm) bun pans: 4
- 9-1/2" x 5" (241mm x 127mm) bread pans: 48
- 9" x 7" (228mm x 178mm) roll pans: 32
- 19" x 4" (483mm x 102mm) pullman pans: 28
- 13" x 16-1/2" (330mm x 419mm) cup tins: 18
- 20" x 28" (508mm x 711mm) roast pans: 4
- No. 200 pans (324mm x 527mm): 8
- Bean pots #1: 70
- #3: 40
- #6: 24
- 25 lb. (11kg) Turkeys: 5

GAS SUPPLY:

- 3/4" IPS connection at rear of oven
- Manifold Pressure:
 - Natural – 5" W.C.
 - Propane – 10" W.C.
- Inlet Pressure:
 - Natural – 7.0" W.C. min. – 10.5" W.C. max.
 - Propane – 11.0" W.C. min. – 13.0" W.C. max.

MAXIMUM INPUT:

- 951 only 38,000 BTU/hr
- 966 only 50,000 BTU/hr
- Double (951/966) 88,000 BTU/hr

MINIMUM ENTRY CLEARANCE:

- Uncrated 32-1/2" (826mm)
- Crated 36" (914mm)

SHIPPING INFORMATION:

- Approx. Weight:
 - 951 600 lbs. (272kg)
 - 966 630 lbs. (286kg)
 - 951/966 1230 lbs. (558kg)
- Crate sizes:
 - 65" (1651mm) x 32" (813mm) x 46" (1168mm)
 - 65" (1651mm) x 36" (914mm) x 46" (1168mm)

NOTE: The company reserves the right to make substitutions of components without prior notice

BLODGETT OVEN COMPANY

www.blodgett.com

44 Lakeside Avenue, Burlington, VT 05401 • Phone: (802) 658-6600 • Fax: (802) 864-0183