

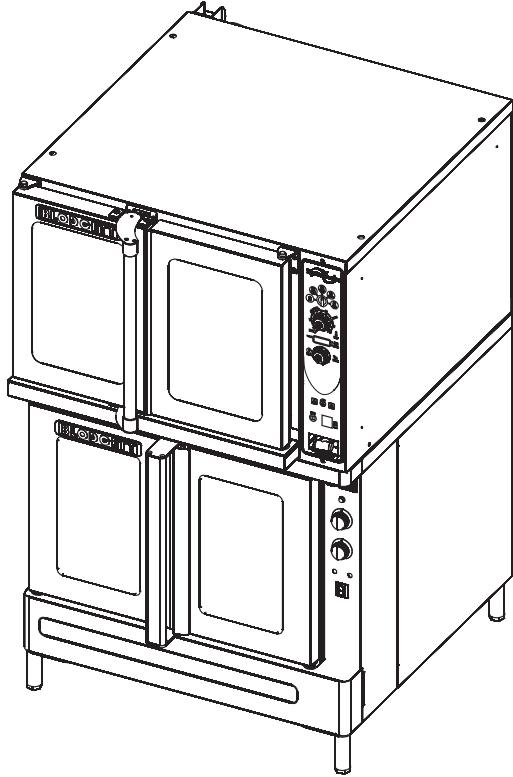

**HV-100E and  
ZEPHAIRE-E PLUS**  
Hydrovection Stacked on a  
Full-Size Electric Convection Oven



Project \_\_\_\_\_

Item No. \_\_\_\_\_

Quantity \_\_\_\_\_

Requires Blodgett stacking kit #52896.

This model consists of a standard HV-100E stacked on a standard Zephaire-E Plus. For more information on each oven refer to the the HV-100E and Zephaire -E Plus specifications sheets.

**HV-100E STACKED ON A ZEPHAIRE-E PLUS**

**SHORT FORM SPECIFICATIONS** Provide Blodgett model HV-100E Hydrovection stacked on a model ZEPHAIRE E PLUS full-size electric convection oven.

**HV-100E Hydrovection** - Shall have fully welded 316 stainless steel liner. Liner to be coved top and bottom. Unit shall accept five 18" x 26" standard full-size bake pans. Doors shall be triple mounted, stainless steel with dual pane thermal glass windows, single tubular handle and simultaneous operation. Unit shall be electrically heated by six tubular heaters. Air in baking chamber distributed by single inlet blower wheel powered by a four speed, auto-reversing, 1/2 HP motor with thermal overload protection. Each chamber shall be fitted with bright halogen lamps, and five standard stainless steel removable racks. Unit shall have manual control with hydro low and hydro high moisture control, hot air and cool down modes. Breaker shut off switch on front panel for easy service. 1 year parts and 1 year labor warranty.

**Zephaire E Plus** - Shall have porcelainized steel liner and shall accept five 18" x 26" standard full-size bake pans in left-to-right or front-to-back positions. Doors shall have dual pane thermal glass windows with single porcelain handle and simultaneous operation. Unit shall be electrically heated with three tubular heaters. Air in baking chamber distributed by single inlet blower wheel powered by a two-speed, 1/3 HP motor with thermal overload protection. Each chamber shall be fitted with five chrome-plated removable racks. Control panel shall be recessed with Cook/Cool Down mode selector, solid state manual infinite thermostat (200 - 500°F), and 60-minute timer. 1 year parts and 1 year labor, three year limited door warranty.

*HV-100E Approvals*



*Zephaire-E Plus Approvals*



**SHIPPING INFORMATION:**

**Approximate Weight:**

HV-100E 450 lbs. (204 kg)

Zephaire E Plus 545 lbs. (247 kg)

**Crate size:**

Each section 37-1/2" (952mm) x 43-1/2" (1105mm) x 52" (1321mm)

**BLODGETT OVEN COMPANY**

www.blodgett.com

44 Lakeside Avenue, Burlington, VT 05401 • Phone: (802) 658-6600 • Fax: (802) 864-0183



# HV-100E STACKED ON A ZEPHAIRE-E PLUS

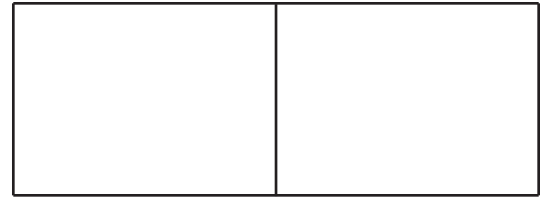

APPROVAL/STAMP

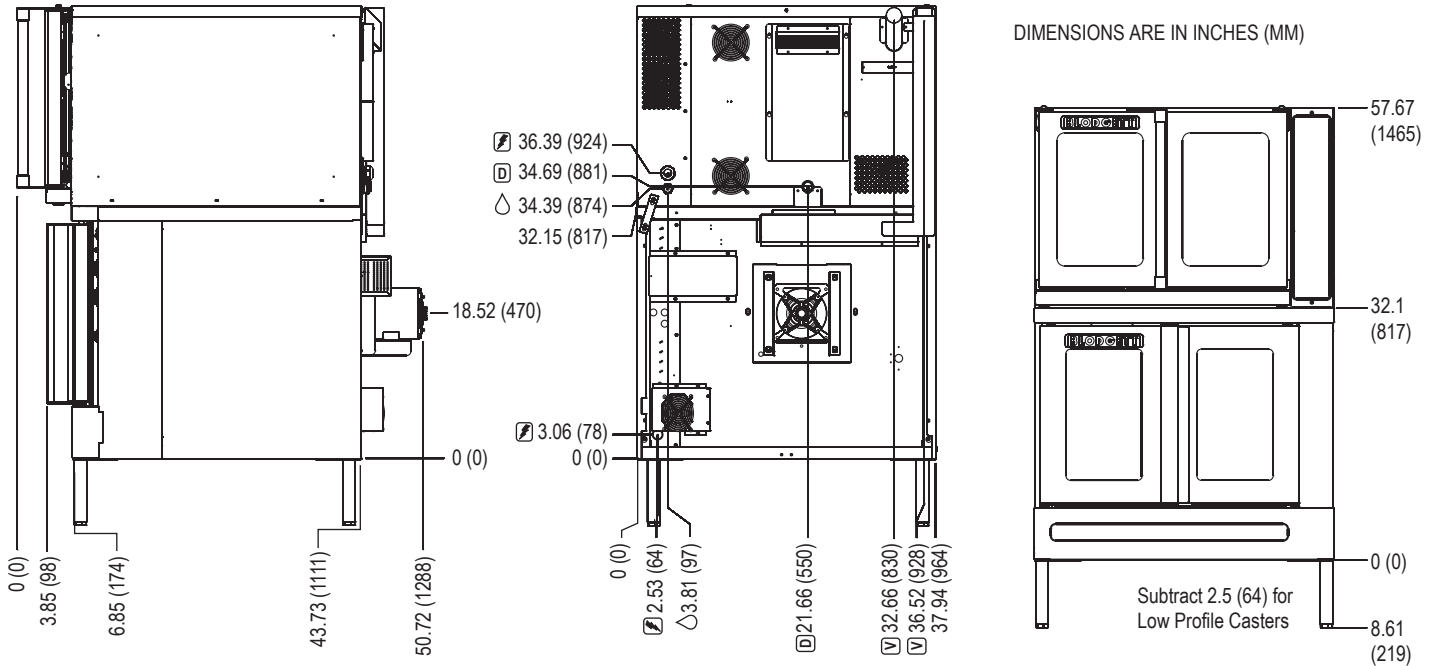

## DIMENSIONS:

### Product Clearance:

Oven sides 1/2" (13mm) Blodgett recommends 4" clearance from any heat source on the control panel side of the oven, an optional heat shield should be considered

Oven back 6" (152mm)

## POWER SUPPLY - ZEPHAIRE E PLUS

V.A.C.	Hz	Phase	kW	Amperes (L1-L2-L3)
208	60.	1	11	51/0/51
208	60	3	11	31/29/29
220/240	60	1	11	44/0/44
220/240	60	3	11	26/24/24
440	60	3	11	15/14/14
480	60	3	11	14/13/13

1/3 HP, 2 speed motor, 1140 & 1725 rpm (60 Hz)

(50 Hz. ovens for 400/230, 380Y/220 VAC or 415Y/240 VAC (4 wire) 3 phase)

This oven contains a mercury relay. DO NOT put mercury relay in trash. Relay must be recycled or disposed of as hazardous waste.

## POWER SUPPLY - HV-100E:

V.A.C.	Hz	Phase	kW	Amperes (L1-L2-L3)
<b>Standard</b>				
208	60	3	15	38/38/38
240	60	3	15	36/34/34
440	60	3	15	20/18/18
480	60	3	15	18/17/17
<b>Option</b>				
208	60	3	13	33/33/36
240	60	3	13	31/29/29
440	60	3	13	16/16/17
480	60	3	13	15/15/16

1/2 H.P., 3 phase motor

## WATER SUPPLY (HV-100E only):

TDS: < 100 ppm      Hardness: 80-120 ppm      pH: 7.0 - 8.0  
 Chlorides: < 30 ppm      Chlorine: 0 ppm      30(min)-50(max) PSI  
 Avg Drain Temp 140°F (60°C)  
 Water Consumption 2.5 - 3.0 GPH  
 Appliance is to be installed with backflow protection in accordance with Federal, State or Local codes.

**NOTE:** The company reserves the right to make substitutions of components without prior notice

## BLODGETT OVEN COMPANY

www.blodgett.com 44 Lakeside Avenue, Burlington, VT 05401 • Phone: (802) 658-6600 • Fax: (802) 864-0183