



BCH-E

Electric Cabinet Based Braising Pan with Heavy Duty Hydraulic Tilt



OPTIONS AND ACCESSORIES

(AT ADDITIONAL CHARGE)

- **Voltage options**
 - 380VAC, 3 phase, 60 Hz
 - 480VAC, 3 phase, 60 Hz
 - 600VAC, 3 phase, 60 Hz
- **Faucets**
 - Single pantry faucet with swing spout
 - Double pantry faucet with swing spout
- **Etched markings**
 - Gallons
 - Litres
- 18 KW elements (40 gallon model only)
- Steam pan insert
- Pan carrier
- Correctional package

Project _____

Item No. _____

Quantity _____

- Model BCH-30E (30 gallon electric braising pan with hydraulic tilt)
- Model BCH-40E (40 gallon electric braising pan with hydraulic tilt)

CONSTRUCTION

- #4 Satin finish 10 gauge stainless steel pan with polished interior, front hinged for easy tilting
- Coved corners
- 5/8" thick stainless steel clad plate
- Tubular heating elements clamped to underside of pan
- Cabinet base of heavy duty welded angle frame with bullet feet on front legs and flanged adjustable feet on back legs
- 304 stainless steel removable side panels and two front doors on cabinet base

OPERATION

- Controls mounted in cabinet base
- Power switch
- Thermostat
- Cook indicator light
- Tilt switch
- Tilt safety switch
- 160-445°F (71-229°C) temperature range

STANDARD FEATURES

- 1/2 HP hydraulic tilting system for smooth and precise tilting action
- Spring assist hinged stainless steel cover with handle
- No drip condensate guide
- Removable pour strainer
- Manual control
- Standard voltages
 - 208VAC, 3 phase, 60 Hz (convertible to 1 phase)
 - 240VAC, 3 phase, 60 Hz (convertible to 1 phase)
- One year parts and labor warranty*

* For all international markets, contact your local distributor.



BCH-E BRAISING PAN WITH HYDRAULIC TILT

BLODGETT COMBI

www.blodgett.com

44 Lakeside Avenue, Burlington, VT 05401 • Phone: (802) 658-6600 • Fax: (802) 864-0183



BCH-E ELECTRIC BRAISING PAN WITH HYDRAULIC TILT



APPROVAL/STAMP

DIMENSIONS ARE IN INCHES [MM]

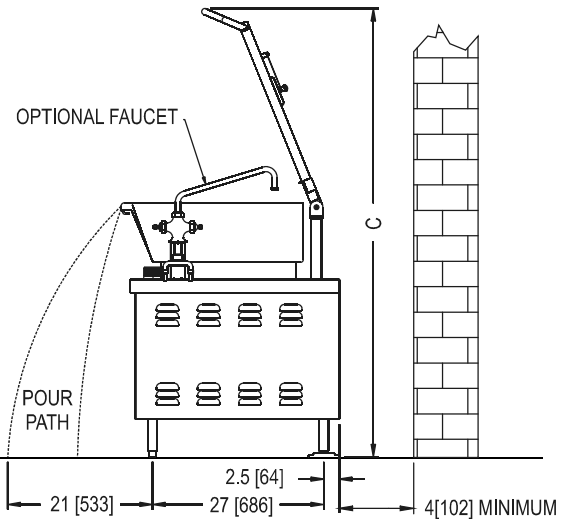
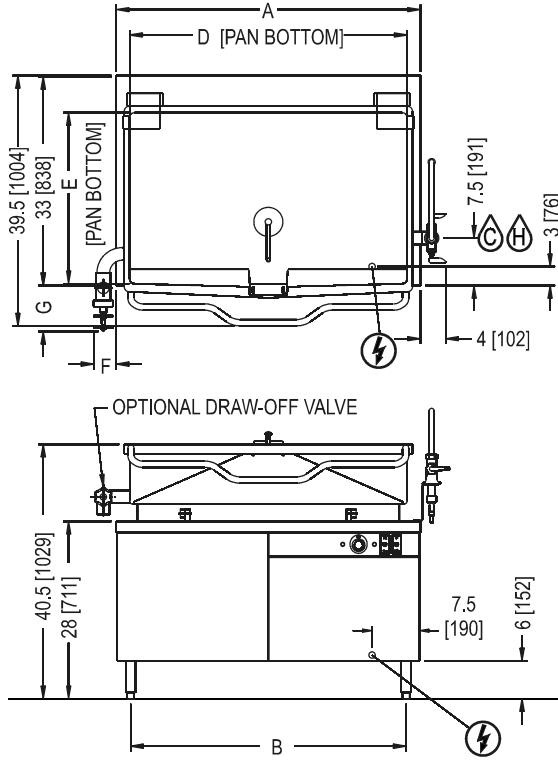

MODEL	A	B	C	D	E	VALVE DIAMETER	F	G
BCH-30E	36[914]	30[762]	70.88[1800]	33.5[851]	23.5[597]	2"	3.6[92]	7.3[186]
BCH-40E	48[1219]	42[1067]	70.88[1800]	43.5[1105]	23[584]	3"	5.5[140]	13.1[333]

SHORT FORM SPECIFICATIONS

Provide Blodgett model BCH-30E, 30 gallon (114 litre) or BCH-40E (152 litre) electric cabinet base braising pan with heavy duty hydraulic tilt. The unit shall have a one-piece covered corner, 10 gauge stainless steel pan with #4 exterior finish and polished interior. The pan sides shall slope outward to facilitate access to the cooking surface. The pan body shall be front hinged for tilting and easy pour control. Cooking surface shall be 5/8" thick stainless steel clad plate ensuring even heat distribution over entire cooking surface. Unit shall be mounted on a heavy duty welded angle construction frame with front legs fitted with adjustable bullet feet and rear legs fitted with flange adjustable feet for securing to the floor. The cabinet base shall be enclosed with #4 finish type 304 stainless steel with removable side panels and two stainless steel front cabinet doors. Tilting is controlled by a 1/2 HP hydraulic tilting system for smooth and precise tilting action. The controls shall be mounted in the cabinet base and shall include a power switch, tilt switch, thermostat with range of 160-445°F (71-229°C), and a cook indicator light. Unit shall include spring assisted hinged stainless steel cover, with handle, no drip condensate guide and removable pour strainer. Provide options and accessories as indicated.

MAXIMUM INPUT:

BCH-30E 12 kW
 BCH-40E 15 kW (18 kW optional)

ELECTRICAL CONNECTION:

Field wire electrical to be as per appliance rating plate

WATER CONNECTION

Hot and Cold water 3/8" O.D. tubing to optional faucet

SHIPPING INFORMATION:

Approx. Weight:

BCH-30E 665 lbs. (302 kg)
 BCH-40E 820 lbs. (372 kg)

		AMPS PER LINE					
kW	Phase	208V	220V	240V	380V	480V	600V
12 kW	1	57.7	54.5	50	N/A	N/A	N/A
	3	33.3	31.5	28.9	18.2	14.4	12.7
15 kW	1	72.1	68.2	62.5	N/A	N/A	N/A
	3	41.6	39.4	36.1	22.8	18	15.6
18 kW Option	1	86.5	81.8	75	N/A	N/A	N/A
	3	50	47.2	43.3	27.3	21.7	18.5

NOTE: The company reserves the right to make substitutions of components without prior notice.

BLODGETT COMBI

www.blodgett.com

44 Lakeside Avenue, Burlington, VT 05401 • Phone: (802) 658-6600 • Fax: (802) 864-0183