



## BLP-E

Electric Floor Model Braising Pan with Power Tilt



Project \_\_\_\_\_

Item No. \_\_\_\_\_

Quantity \_\_\_\_\_

- Model BLP-30E (30 gallon electric braising pan with power tilt)
- Model BLP-40E (40 gallon electric braising pan with power tilt)

### CONSTRUCTION

- #4 finish 10 gauge stainless steel pan with polished interior, front hinged for easy tilting
- Coved corners
- 5/8" thick stainless steel clad plate
- Tubular heating elements clamped to underside of pan
- Welded stainless steel pipe frame with bullet feet on front legs and flanged adjustable feet on back legs
- Front control console

### OPERATION

- Integrally mounted controls
- Power switch
- Thermostat
- Cook indicator light
- High temperature cut-off
- Tilt switch
- 160-445°F (71-230°C) temperature range

### STANDARD FEATURES

- Electric motor driven screw jack for smooth and precise tilting
- Spring assist hinged stainless steel cover with handle
- No drip condensate guide
- Removable pour strainer
- Manual control
- Standard voltage options
  - 208 VAC, 1 phase, 60 Hz
  - 240 VAC, 1 phase, 60 Hz
  - 208 VAC, 3 phase, 60 Hz
  - 240 VAC, 3 phase, 60 Hz
- One year parts and labor warranty\*

\* For all international markets, contact your local distributor.

### OPTIONS AND ACCESSORIES

(AT ADDITIONAL CHARGE)

- **Voltage options**
  - 220 VAC, 1 phase, 60 Hz
  - 220 VAC, 3 phase, 60 Hz
  - 220/380 VAC, 3 phase, 60 Hz
  - 240/415 VAC, 3 phase, 60 Hz
  - 480 VAC, 3 phase, 60 Hz
  - 600 VAC, 3 phase, 60 Hz
- **Faucets**
  - Single pantry faucet with swing spout
  - Double pantry faucet with swing spout
- **Etched markings**
  - Gallons
  - Litres
- Steam pan insert
- Pan carrier
- Correctional package



BLP-E BRAISING PAN WITH POWER TILT

### BLODGETT

www.blodgett.com

44 Lakeside Avenue, Burlington, VT 05401 • Phone: (802) 658-6600 • Fax: (802) 864-0183



## BLP-E ELECTRIC BRAISING PAN WITH POWER TILT

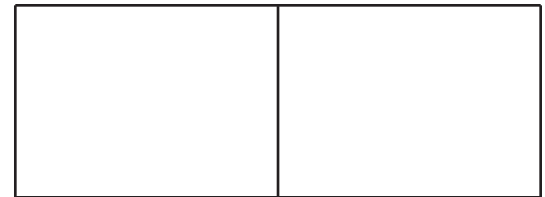

APPROVAL/STAMP

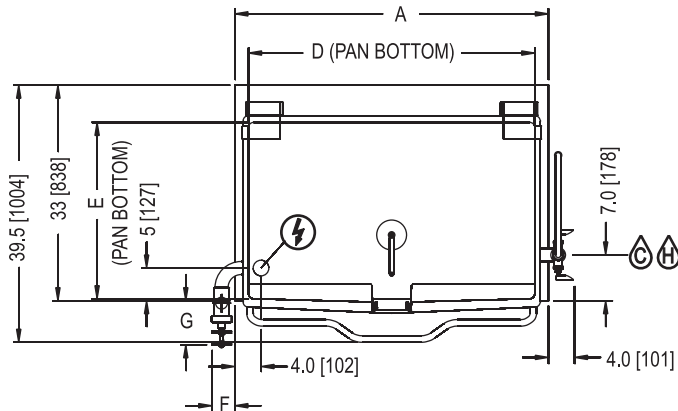

DIMENSIONS ARE IN INCHES [MM]



**REAR FLANGED FOOT DETAIL**  
4 EQUALLY SPACED  
Ø7/16" [11mm] HOLES  
ON 3 [76] B.C.

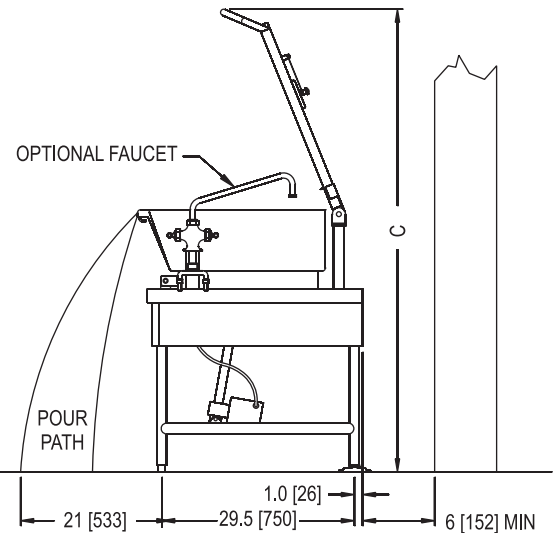
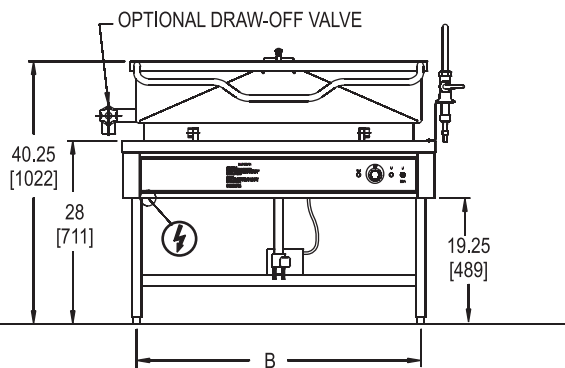

MODEL	A	B	C	D	E	VALVE DIAMETER	F	G
BLP-30E	36[914]	33.5[851]	74[1880]	33.5[851]	23.5[597]	2"	3.6[92]	7.3[186]
BLP-40E	48[1219]	45.5[1156]	74[1880]	43.5[1105]	23[584]	3"	5.5[140]	13.1[333]

### SHORT FORM SPECIFICATIONS

Provide Blodgett model BLP-30E, 30 gallon (114 litre) or BLP-40E (152 litre) electrical braising pan with power tilt. The unit shall have a one-piece covered corner, 10 gauge stainless steel pan with #4 exterior finish and polished interior. The pan body shall be front hinged for tilting and easy pour control. Cooking surface shall be 5/8" thick stainless steel clad plate ensuring even heat distribution over entire cooking surface. The pan shall be fitted with tubular heating elements clamped to the underside. Unit shall be mounted on stainless steel tubular legs with front legs fitted with adjustable bullet feet and rear legs fitted with flange adjustable feet for securing to the floor. Tilting is controlled by an electric motor driven screw jack for smooth and precise tilting action. The controls shall be integrally mounted in the right hand console and shall include a power switch, tilt switch, thermostat with range of 160-445°F (71-230°C), a cook indicator light and high temperature cut-off. Unit shall include spring assisted hinged stainless steel cover, with handle, no drip condensate guide and removable pour strainer. Provide options and accessories as indicated.

### MAXIMUM INPUT:

BLP-30E 12 kW  
BLP-40E 18 kW

### POWER CONNECTION:

Refer to data plate.

### WATER CONNECTION

Hot and Cold water 3/8" O.D. tubing to optional faucet

### SHIPPING INFORMATION:

#### Approx. Weight:

BLP-30E 540 lbs. (245 kg)  
BLP-40E 620 lbs. (281 kg)

		AMPS PER LINE						
kW	Phase	208V	220V	240V	380V	415V	480V	600V
12 kW	1	57.7	54.5	50	N/A	N/A	N/A	N/A
	3	33.3	31.5	28.9	18.2	16.7	14.4	11.5
15 kW	1	72.1	68.2	62.5	N/A	N/A	N/A	N/A
	3	41.6	39.4	36.1	22.8	20.9	18	14.4
18 kW Option	1	86.5	81.8	75	N/A	N/A	N/A	N/A
	3	50	47.2	43.3	27.3	25.0	21.7	17.3

**NOTE:** The company reserves the right to make substitutions of components without prior notice.

**BLODGETT**

www.blodgett.com 44 Lakeside Avenue, Burlington, VT 05401 • Phone: (802) 658-6600 • Fax: (802) 864-0183