



BTT-12E

Electric Countertop Tilting Braising Pan



OPTIONS AND ACCESSORIES

(AT ADDITIONAL CHARGE)

- Voltage options
 - 380 VAC, 3 phase, 60 Hz
 - 415 VAC, 3 phase, 60 Hz
 - 220/380 VAC, 4 wire
 - 240/415 VAC, 4 wire
 - 480 VAC, 3 phase, 60 Hz
 - 600 VAC, 3 phase, 60 Hz
- Stands
 - 18" (46 mm) high stainless steel stand with sliding shelf
 - 18" (46 mm) high stainless steel stand with sliding drawer and stationary drain
- Faucets
 - Single pantry faucet with swing spout
 - Double pantry faucet with swing spout
- Etched markings
 - Gallons
 - Litres
- Steam pan insert
- Stainless steel lift off cover
- Stainless steel perforated strainer
- Marine lock
- Corrections package

Project _____

Item No. _____

Quantity _____

- Model BTT-12E (12 gallon electric tilting braising pan)

CONSTRUCTION

- Satin finish 10 gauge stainless steel pan with polished interior
- Coved corners
- Stainless steel control housing
- Elements are cast embedded into a full 1-1/2" (38mm) aluminum casting clamped below the pan for even heat distribution
- Side pivots for tilting
- Tilting handle with heat proof knob
- Tilt position double permits tilting during the cook cycle to aid in grease removal
- Concealed mounting lugs for bolting unit to counter top or stand

OPERATION

- Integrally mounted controls
- Power switch
- Thermostat
- Cook indicator light
- High temperature cut-off
- 160-445°F (71-230°C) temperature range

CAPACITY

- 12 gallon (45 litres)

STANDARD FEATURES

- Side pivots and tilting handle
- Manual control
- Mounts to countertop (optional legs available)
- Standard voltage options
 - 208 VAC, 1 or 3 phase, 60 Hz
 - 220 VAC, 1 or 3 phase, 60 Hz
 - 240 VAC, 1 or 3 phase, 60 Hz
- One year parts and labor warranty*

* For all international markets, contact your local distributor.



BTT-12E BRAISING PAN

BLODGETT

44 Lakeside Avenue, Burlington, VT 05401

Toll Free: (800) 331-5842 • Phone: (802) 860-3700 • Fax: (802) 864-0183



BTT-12E ELECTRIC COUNTERTOP TILTING BRAISING PAN

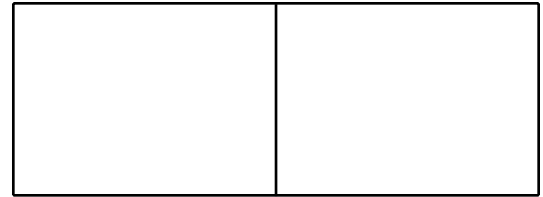

APPROVAL/STAMP

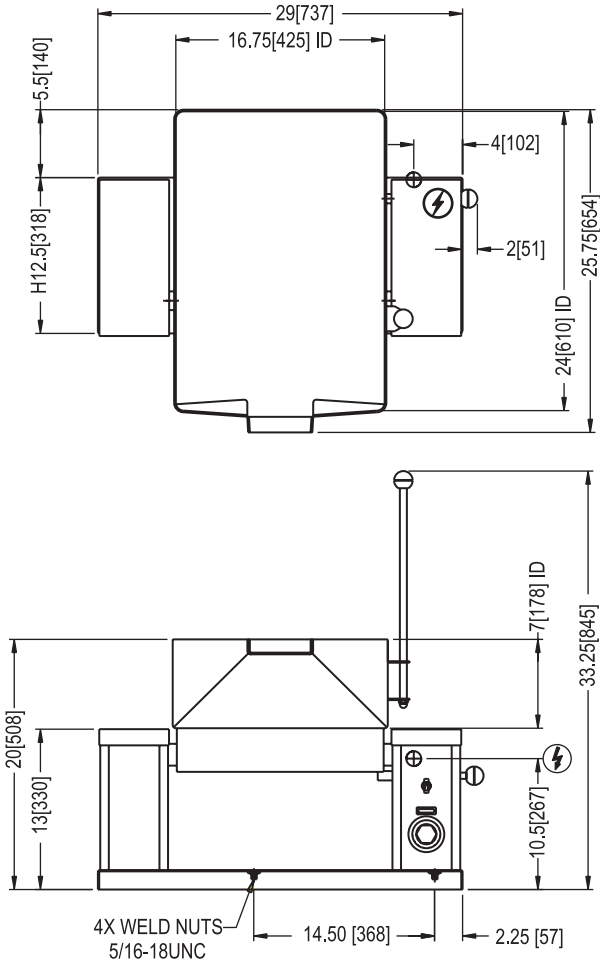

DIMENSIONS ARE IN INCHES [MM]

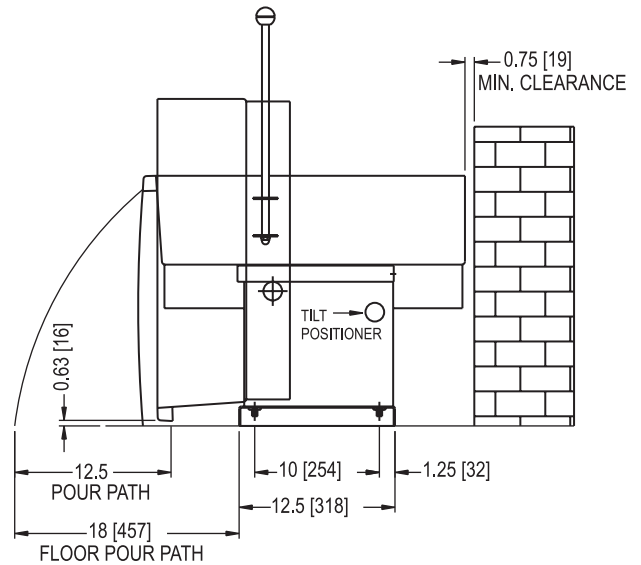

SHORT FORM SPECIFICATIONS

Provide Blodgett model BTT-12E, 12 gallon (45 litre) electrically heated counter tilting braising pan. The unit shall have a one-piece covered corner, 10 gauge stainless steel pan with #4 finish exterior and polished interior. Heating shall be accomplished by electric elements cast embedded into a full 1-1/2" (38mm) thick aluminum casting attached to the underside of the pan. The pan shall be mounted on side pivots to allow tilting and shall have a tilting handle with heat proof knob. A tilt position device shall permit the pan to be tilted forward slightly during cooking to aid grease removal. Unit shall have concealed mounting lugs for bolting to a counter top or stand. The controls shall be integrally mounted in the stainless steel housing and shall include a power switch, thermostat with range of 160-445°F (71-230°C), a cook indicator light and high temperature cut-off. Provide options and accessories as indicated.

MAXIMUM INPUT:

BTT-12E 9 kW

POWER CONNECTION:

Refer to data plate.

This unit contains a mercury relay. DO NOT put mercury relay in trash. Relay must be recycled or disposed of as hazardous waste.

SHIPPING INFORMATION:

Approx. Weight:

BTT-12E 220 lbs. (100 kg)

		AMPS PER LINE						
kW	Phase	208V	220V	240V	380V	415V	480V	600V
9	1	43.3	40.9	37.5	N/A	N/A	N/A	N/A
	3	25.0	23.6	21.7	13.7	12.5	10.8	8.7

NOTE: The company reserves the right to make substitutions of components without prior notice.

BLODGETT

44 Lakeside Avenue, Burlington, VT 05401

Toll Free: (800) 331-5842 • Phone: (802) 860-3700 • Fax: (802) 864-0183