

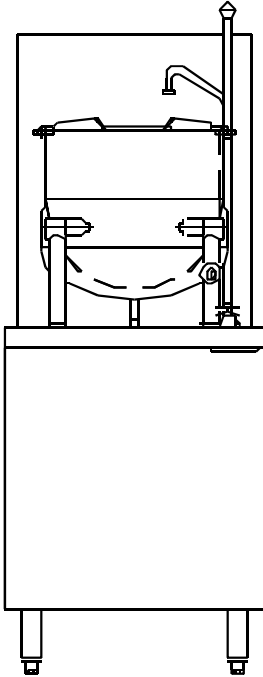

**CB24G-K**  
One Direct Steam Kettle  
on a 24" Gas Boiler Base



**OPTIONS AND ACCESSORIES**

(AT ADDITIONAL CHARGE)

- Power Increase
  - 200,000 BTU boiler
  - 250,000 BTU boiler in a 36" wide cabinet
  - 300,000 BTU boiler in a 36" wide cabinet
- Etched kettle markings
  - Gallon markings
  - Litre markings
- 36" wide cabinet for 140,000 and 200,000 models
- Front flanged feet
- Correctional package
- Stainless steel back panel
- 208-240 VAC *specify voltage*
- One year extended warranty

Project \_\_\_\_\_

Item No. \_\_\_\_\_

Quantity \_\_\_\_\_

- Model CB24G-6K (one 6 gallon direct steam kettle on a 24" gas boiler base)
- Model CB24G-10K (one 10 gallon direct steam kettle on a 24" gas boiler base)

**KETTLES**

- Water resistant, 304 stainless steel construction
- 316 stainless steel interior cooking surface for corrosion resistance
- 2/3 jacketed, hemispherical design on bottom for superior heat circulation
- Tilt mechanism permits kettle to tilt forward past 90° to empty
- Tubular stainless steel legs containing steam control valve and condensate return pipes
- Reversible operating handle with heat proof knob

**GAS BOILER BASE**

- Gas operated steam boiler rated at 15 PSI (103 kPa) operating on 115VAC, 1 phase, 60 Hz rated at 140,000 BTU
- Full perimeter painted angle iron frame
- Reinforced counter and boiler mountings
- Stainless steel exterior
- Hinged door(s) with magnetic latch
- 6" (152 mm) stainless steel legs with adjustable bullet feet on front and adjustable flanged feet on rear
- Thermostatically controlled drain box
- All piping is confined within cabinet
- Automatic water level control
- Automatic boiler blowdown
- Pressure gauge
- Water gauge glass
- Pressure control with pressure safety control
- Safety relief valve
- Cathodic protector
- On/Off switch with indicator light
- Electronic ignition
- Split water lines
- CSD-1 secondary low water cut off

**STANDARD FEATURES**

- Deck mount hot and cold faucet with riser
- 3"(76mm) deep sinks with splash guards and grates
- Startup inspection service by factory authorized service agent
- One year parts and labor warranty\*

\* For all international markets, contact your local distributor



**CB24G-K GAS BOILER BASE WITH KETTLE**

**BLODGETT**

[www.blodgett.com](http://www.blodgett.com)

44 Lakeside Avenue, Burlington, VT 05401 • Phone: (802) 658-6600 • Fax: (802) 864-0183



# CB24G-K

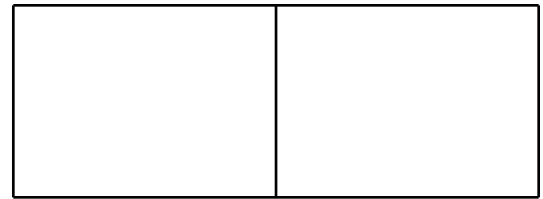

APPROVAL/STAMP

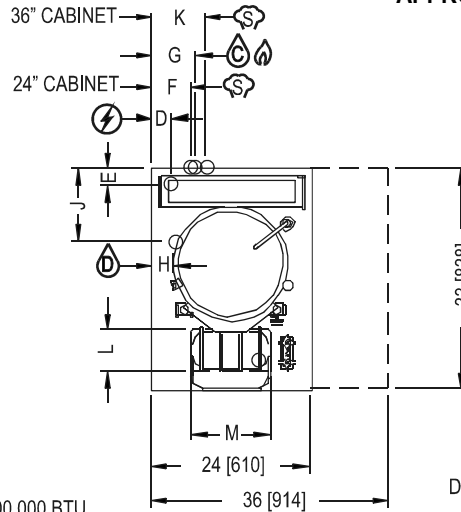
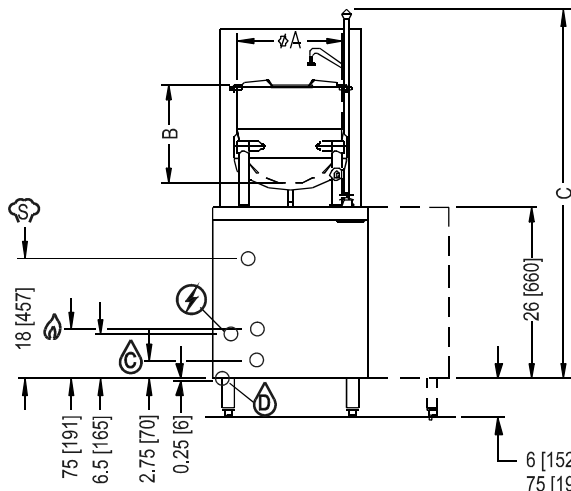

**REAR FLANGED FOOT DETAIL**  
 2 EQUALLY SPACED  
 Ø7/16" [11mm] HOLES  
 ON 2.5 [63] B.C.

DIMENSIONS ARE IN INCHES [MM]

NOTE: SPLASH GUARD NOT SHOWN ON FRONT VIEW

24" CABINET, 200,000 BTU

MODEL	A	B	C	D	E	F	G	H	J	K	L	M
CB24G-6K	12 (305)	14.5 (368)	56.75 (1441)	3 (76)	2.5 (64)	5.75 (146)	4.75 (121)	3.5 (89)	11 (279)	8 (203)	9 (229)	12 (305)
CB24G-10K	16 (406)	15 (381)	55.75 (1416)								6 (152)	

### SHORT FORM SPECIFICATIONS

Provide Blodgett model CB24G-6K (6 pan) one 6 gallon direct steam kettle or model CB24G-10K (6 pan) one 10 gallon direct steam kettle on a 140,000 BTU gas boiler base base. The kettles shall have a double wall interior to form a steam jacket around the lower 2/3 of the kettle. The bottom of the kettle shall be of hemispherical design for superior heat circulation. Steam control valve mounted in leg. The tubular stainless steel mounting legs shall have the steam supply and condensate return pipes completely concealed within the leg members. The sealed stainless steel tilt mechanism bearings shall permit the kettle to tilt forward 90° for complete emptying. A removeable operating handle with heat proof knob shall be mounted on the left or right. Unit shall have a single support leg with nylon insert. Construction shall be all welded satin finish 304 stainless steel with a 316 stainless steel liner. The boiler shall be suitable for operation at any pressure from 5-11 PSI (34-76 kPa) and operate on 115 VAC. Boiler shall be mounted in cabinet base. Polished stainless steel cabinet base shall be of modular design to match other Blodgett steam equipment. Unit shall have 6" (152mm) stainless steel legs and adjustable bullet feet, reinforced stainless steel counter top and hinged doors with magnetic latches. All piping shall be confined within the cabinet. Unit shall be automatically filled with water and brought to pressure when power switch is turned on. Cold water condenser shall automatically condense exhausted steam in water before releasing it to drain. Boiler controls shall include automatic water level, pressure gauge, water gauge glass, pressure control with pressure safety control, safety relief valve, cathodic protector and CSD-1 secondary low water cut off. Unit shall have a hot and cold water faucet with control valves, 5" (152 mm) deep sink with drain and two splash guards. Kettles and boiler shall be ASME code stamped and National Board registered. Provide options and accessories as indicated.

### WATER SUPPLY:

Water quality is a major factor affecting the performance of your steamer. If you are unsure of water quality, consult a local water treatment specialist and have the water analyzed. Your water supply must be within these general guidelines:

Total dissolved solids:	Less than 60 PPM	Total alkalinity:	Less than 20 PPM
Silica:	Less than 13 PPM	Chlorine:	Less than 1.5 PPM
pH Factor:	7.0 - 8.5		

Water which fails to meet these standards should be treated by installation of a water conditioner. Failure or malfunction of this steamer due to poor water quality is not covered under warranty.

### WATER & DRAIN CONNECTIONS:

- Drain 2" (51mm) IPS piped to open floor drain. No solid connection. 24" length before open air opening (no bends or elbows)
  - Cold Water 3/8" (10mm) tubing at 25-50 PSI (170-345 kPa)
  - Steam Take Off 3/4" IPS optional to operate adjacent equipment
- Appliance is to be installed with backflow protection in accordance with Federal, State or Local codes.

**NOTE:** The company reserves the right to make substitutions of components without prior notice.

### GAS SUPPLY:

- 3/4" IPS supply line required
- Minimum Inlet Pressure:**
  - Natural 7.0" W.C. static to unit
  - Propane 11.0" W.C. static to unit

### POWER SUPPLY:

Unless otherwise specified, field wire electrical connection to be 120VAC, single phase, 60 Hz with grounding wire.

### PRODUCT CLEARANCE

- Right and Left side 3" (76mm)
- Rear 6" (152mm)

### SHIPPING INFORMATION:

- Approx. Weight:**
  - CB24G-6K 450 lbs. (204 kg)
  - CB24G-10K 470 lbs. (213 kg)

**BLODGETT**

www.blodgett.com 44 Lakeside Avenue, Burlington, VT 05401 • Phone: (802) 658-6600 • Fax: (802) 864-0183