

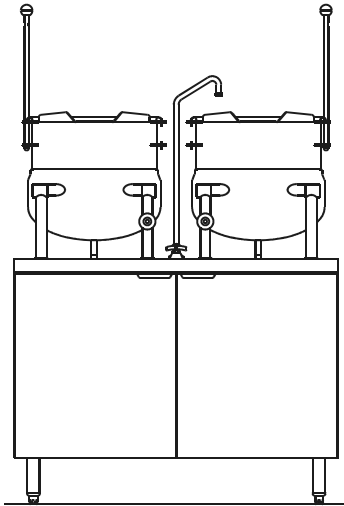

**CB42E-10-10K**  
Two Direct Steam Kettles  
on a 42" Electric Boiler Base



Project \_\_\_\_\_

Item No. \_\_\_\_\_

Quantity \_\_\_\_\_

- Model CB42E-10-10K (Two 10 gallon direct steam kettles on a 42" electric boiler base)

**KETTLES**

- Water resistant, 304 stainless steel construction
- 316 stainless steel interior cooking surface for corrosion resistance
- 2/3 jacketed, hemispherical design on bottom for superior heat circulation
- Tilt mechanism permits kettle to tilt forward past 90° to empty
- Tubular stainless steel legs containing steam control valve and condensate return pipes
- Reversible operating handle with heat proof knob

**ELECTRIC BOILER BASE**

- 24 kW electric boiler base
- Full perimeter painted angle iron frame
- Reinforced counter and boiler mountings
- Stainless steel exterior
- Hinged door(s) with magnetic latch
- 6" (152 mm) stainless steel legs with adjustable bullet feet on front and adjustable flanged feet on rear
- All piping is confined within cabinet
- Automatic water level control
- Automatic boiler blowdown
- Pressure gauge
- Water gauge glass
- Pressure control with pressure safety control
- Safety relief valve
- Cathodic protector
- Steam trap
- On/Off switch with indicator light
- Split water lines
- CSD-1 secondary low water cut off

**STANDARD FEATURES**

- Deck mount hot and cold faucet with riser
- 3"(76mm) deep sinks with splash guard and grates
- Standard voltage options
  - 208 VAC, 3 phase, 60 Hz
  - 208 VAC, 1 phase, 60 Hz (24kW ONLY)
  - 240 VAC, 3 phase, 60 Hz
  - 240 VAC, 1 phase, 60 Hz (24kW only)
- Startup inspection service by factory authorized service agent
- One year parts and labor warranty\*

\* For all international markets, contact your local distributor

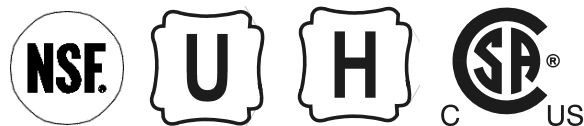

**CB42E-10-10K ELECTRIC BOILER BASE WITH KETTLES**

**OPTIONS AND ACCESSORIES**  
(AT ADDITIONAL CHARGE)

- **Voltage Options**
  - 220 VAC, 3 phase, 60 Hz
  - 380 VAC, 3 phase, 60 Hz
  - 415 VAC, 3 phase, 60 Hz
  - 480 VAC, 3 phase, 60 Hz
  - 415/240 VAC, 3 phase, 4 wire
  - 380/220 VAC, 3 phase, 4 wire
  - 600 VAC, 3 phase, 60 Hz
- **Increased Rating Options**
  - 36 kW
  - 42 kW
  - 48 kW (N/A in 208 or 220 VAC)
- **Etched kettle markings**
  - Gallon markings
  - Litre markings
- Correctional package
- Stainless steel back panel
- Steam take off kit
- Water in "Y" strainer
- Pour lip strainer
- One piece stainless steel lift off cover
- Lift out perforated basket
- Graduated measuring strip
- One year extended warranty

**BLODGETT**

[www.blodgett.com](http://www.blodgett.com)

44 Lakeside Avenue, Burlington, VT 05401 • Phone: (802) 658-6600 • Fax: (802) 864-0183



# CB42E-10-10K

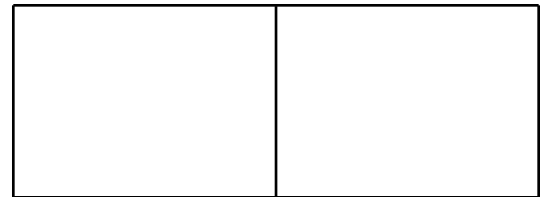

APPROVAL/STAMP

DIMENSIONS ARE IN INCHES [MM]

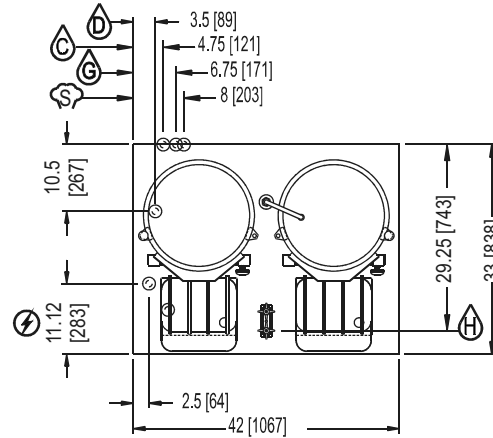
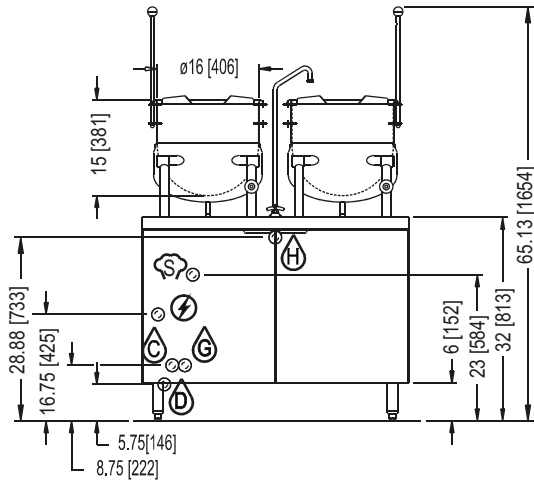

**REAR FLANGED FOOT DETAIL**  
2 EQUALLY SPACED  
Ø7/16" [11mm] HOLES  
ON 2.5 [63] B.C.

NOTE: SPLASH GUARD NOT SHOWN ON FRONT VIEW

- Field wire electrical connection to be as specified on rating plate.
- STEAM TAKE-OFF CONNECTION: 3/4" IPS optional to operate adjacent equipment
- GENERATOR WATER: 3/8" O.D. tubing at 25-50 PSI (170-345 kPa)
- DRAIN: 2" IPS piped to open floor drain. No solid connection.
- COLD WATER: condensing drain and water faucet, 3/8" O.D. tubing at 25-50 PSI (170-345 kPa)
- HOT WATER: 3/8" O.D. tubing at 25-50 PSI (170-345 kPa)

### SHORT FORM SPECIFICATIONS

Provide Blodgett model CB42E-10-10K, two 10 gallon direct steam kettles on a 42" wide electric boiler base.

The kettles shall have a double wall interior to form a steam jacket around the lower 2/3 of the kettle. The bottom of the kettle shall be of hemispherical design for superior heat circulation. Steam control valve mounted in leg. The tubular stainless steel mounting legs shall have the steam supply and condensate return pipes completely concealed within the leg members. The sealed stainless steel tilt mechanism bearings shall permit the kettle to tilt forward 90° for complete emptying. A removeable operating handle with heat proof knob shall be mounted on the left or right. Unit shall have a single support leg with nylon insert. Construction shall be all welded satin finish 304 stainless steel with a 316 stainless steel liner.

The boiler shall be 24 kW, 42" wide electric steam boiler cabinet. Polished stainless steel cabinet base shall be of modular design to match other Blodgett steam equipment. Unit shall have 6" (152mm) stainless steel legs, adjustable bullet feet on front and adjustable flanged feet on rear, reinforced stainless steel counter top and hinged doors with magnetic latches. All piping shall be confined within the cabinet. Unit shall be automatically filled with water and brought to pressure when power switch is turned on. Cold water condenser shall automatically condense exhausted steam in water before releasing it to drain. Boiler controls shall include automatic water level, pressure gauge, water gauge glass, pressure control with pressure safety control, safety relief valve, cathodic protector and CSD-1 secondary low water cut off.

Unit shall have a hot and cold water faucet with control valves, 3" (76 mm) deep sinks with drain and splash guards.

Kettles and boiler shall be ASME code stamped and National Board registered. Provide options and accessories as indicated.

### WATER SUPPLY:

Water quality is a major factor affecting the performance of your steamer. If you are unsure of water quality, consult a local water treatment specialist and have the water analyzed. Your water supply must be within these general guidelines:

- Total dissolved solids: Less than 60 PPM
- Total alkalinity: Less than 20 PPM
- Silica: Less than 13 PPM
- Chlorine: Less than 1.5 PPM
- pH Factor: 7.0 - 8.5

Water which fails to meet these standards should be treated by installation of a water conditioner. Failure or malfunction of this steamer due to poor water quality is not covered under warranty.

### WATER & DRAIN CONNECTIONS:

Drain 2" (51mm) IPS piped to open floor drain. No solid connection.  
24" length before open air opening (no bends or elbows)

Cold Water 3/8" (10mm) tubing at 25-50 PSI (170-345 kPa)

Steam Take Off 3/4" IPS optional to operate adjacent equipment

Appliance is to be installed with backflow protection in accordance with Federal, State or Local codes.

### ELECTRICAL CHARACTERISTICS

kW	PH	AMPS PER LINE						
		208V	220V	240V	380V	415V	480V	600V
24	1	115.4	109.1	100	n/a	n/a	n/a	n/a
	3	66.6	63	57.7	36.5	33.4	28.9	23.1
36	3	99.9	94.5	86.6	54.7	50.1	43.3	34.6
42	3	116.6	110.2	101	63.8	58.4	50.5	40.5
48	3	n/a	n/a	115.5	72.9	66.8	57.7	46.2

### SHIPPING INFORMATION:

Approx. Weight:

CB42E-10-10K 720 lbs. (327 kg)

NOTE: The company reserves the right to make substitutions of components without prior notice.

**BLODGETT**

www.blodgett.com

44 Lakeside Avenue, Burlington, VT 05401 • Phone: (802) 658-6600 • Fax: (802) 864-0183