

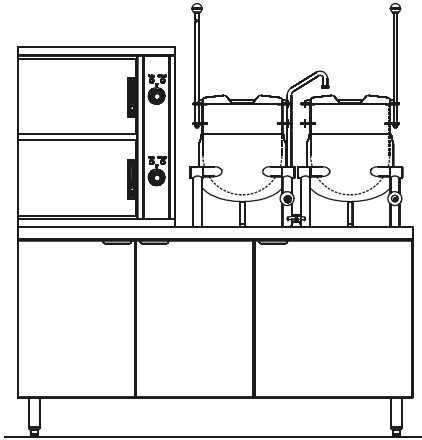

SB-E-6-6K

Convection Steamer with Two Kettles
on an Electric Boiler Base



OPTIONS AND ACCESSORIES

(AT ADDITIONAL CHARGE)

- **Voltage Options**
 - 220 VAC, 1 phase, 60 Hz
 - 380 VAC, 3 phase, 60 Hz
 - 415 VAC, 3 phase, 60 Hz
 - 480 VAC, 3 phase, 60 Hz
 - 240/415 VAC, 3 phase, 4 wire
 - 220/380 VAC, 3 phase, 4 wire
- 48 kW
- Stainless steel frame
- Stainless steel rear panel
- Correctional package
- Steam take off kit
- Water in "Y" strainer
- Spray and rinse assembly
- Load compensation timer
- Adjustable front flanged feet
- One year extended warranty



BLODGETT

www.blodgett.com

44 Lakeside Avenue, Burlington, VT 05401
Phone: (802) 658-6600 • Fax: (802) 864-0183

Project _____

Item No. _____

Quantity _____

- Model SB-6E-6-6K (two 3 pan convection steamer compartments with two 6 gallon kettles on a 60" wide, 42 kW electric boiler)
- Model SB-10E-6-6K (two 5 pan convection steamer compartments with two 6 gallon kettles on a 60" wide, 42 kW electric boiler)

CONVECTION STEAMER

- 304 satin finish stainless steel
- Welded stainless steel door with removable inner stainless steel liner
- Full perimeter door gasket
- Positive lock and seal mechanism with spring release on door
- Stainless steel control housing
- One piece welded 316 stainless steel cooking chamber with coved corners
- Stainless steel pan supports
- Stainless steel drip trough integrally connected to drain
- Pressureless steam operation
- Separate controls for each compartment
- Controls accessible through removable side panel
- Ready and Cooking indicator lights
- 60 minute electric timer with audible alarm to signal end of cook cycle
- Steam flow to the cooking chamber is cut off when the door is opened during the cooking cycle and reactivated when the door is closed

KETTLE

- Water resistant, 304 stainless steel construction
- 316 stainless steel interior cooking surface for corrosion resistance
- 2/3 jacketed, hemispherical design on bottom for superior heat circulation
- Tilt mechanism permits kettle to tilt forward 90° to empty
- Tubular stainless steel legs containing steam control valve and condensate return pipes
- Reversible operating handle with heat proof knob

ELECTRIC BOILER BASE

- Full perimeter painted angle iron frame
- Reinforced steamer and boiler mountings
- Stainless steel exterior
- Hinged door(s) with magnetic latch
- 6" (152 mm) stainless steel legs with adjustable bullet feet on front and adjustable flanged feet on rear for securing unit to floor
- Automatic water level control
- Automatic boiler blowdown
- Pressure and Water gauges
- Pressure control with pressure safety control
- Safety relief valve
- Cathodic protector
- CSD-1 secondary low water cut off

STANDARD FEATURES

- 208, 240 VAC, 3 phase, 60 Hz for boiler
- Electromechanical controls
- Split water lines
- Startup inspection service by factory authorized service agent
- One year parts and labor steamer warranty*
- Five year limited steamer door warranty*

* For all international markets, contact your local distributor

SB-E-6-6K CONVECTION STEAMER WITH KETTLES



SB-E-6-6K

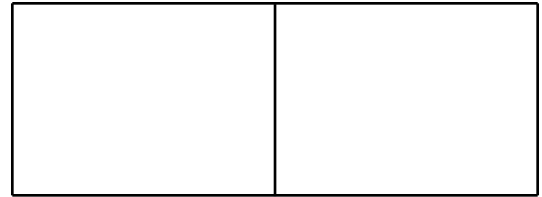

DIMENSIONS ARE IN INCHES [MM]

NOTE: SPLASH GUARD NOT SHOWN ON FRONT VIEW

APPROVAL/STAMP

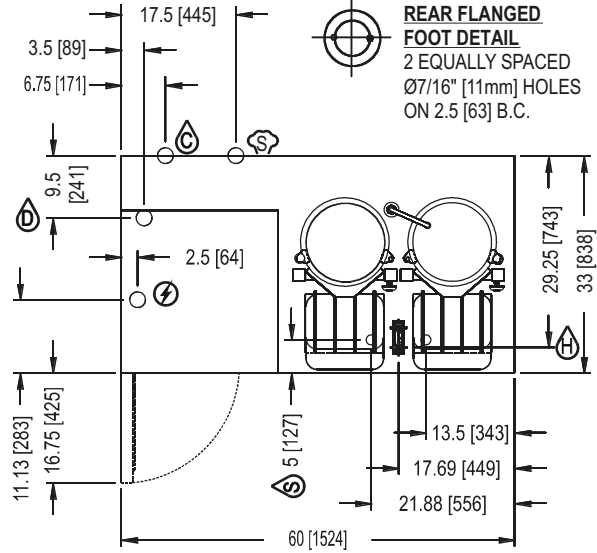
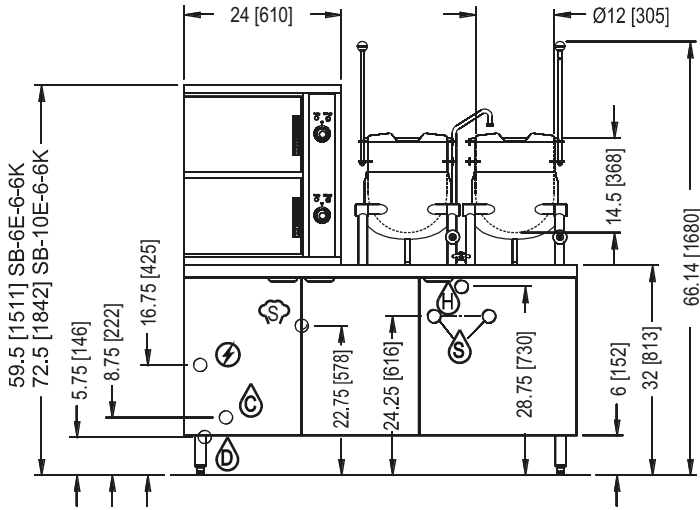

REAR FLANGED FOOT DETAIL
2 EQUALLY SPACED
Ø7/16" [11mm] HOLES
ON 2.5 [63] B.C.

- ELECTRICAL CONNECTION: 1/2" conduit connection to controls. Rating to be specified on data plate.
- HOT AND COLD WATER: 3/8" O.D. tubing at 25-50 PSI (170-345 kPa).
- SINK DRAIN: 1-1/8" O.D. tubing
- STEAM TAKE-OFF CONNECTION: 3/4" IPS optional to operate adjacent equipment.
- DRAIN: 2" IPS piped to open floor drain. No solid connection.

SHORT FORM SPECIFICATIONS

Provide Blodgett model SB-6E-6-6K (6 pan) or SB-10E-6-6K (10 pan) convection steamer with 60" wide, 42 kW electric steam boiler base and two 6 gallon direct steam kettles.

The SB-6E-6-6K is comprised of two 3 pan compartments. The SB-10E-6-6k is comprised of two 5 pan compartments. Steamer shall be constructed of #4 satin finish 304 stainless steel with a one piece welded 316 stainless steel cooking chamber with coved corners. The door shall have a removable inner liner of stainless steel with full perimeter gasket seal, an outer liner of one-piece all welded stainless steel, and a positive lock and seal mechanism with spring release. Each compartment shall have removable stainless steel pan supports. A stainless steel drip trough integrally connected to collect and drain condensate with the doors open. The control housing shall be constructed of stainless steel with a full access removable panel. The controls shall include a ready indicator light, cooking indicator light, and a 60 minute electric timer with audible alarm that signals the end of the cook cycle. Steam flow to the compartment shall be cut off when the door is opened during the cook cycle and shall be reactivated when the door is closed.

The kettles shall have a double wall interior to form a steam jacket around the lower 2/3 of the kettle. The bottom of the kettle shall be of hemispherical design for superior heat circulation. Steam control valve mounted in leg. The tubular stainless steel mounting legs shall have the steam supply and condensate return pipes completely concealed within the leg members. The sealed stainless steel tilt mechanism bearings shall permit the kettle to tilt forward 90° for complete emptying. A removable operating handle with heat proof knob shall be mounted on the left or right. Unit shall have a single support leg with nylon insert. Construction shall be all welded satin finish 304 stainless steel with a 316 stainless steel liner.

The boiler base shall have full perimeter painted angle iron frame, reinforced counter and boiler mountings, electric boiler with controls, automatic boiler blow down, stainless steel exterior, hinged doors and 6" (152 mm) stainless steel legs with adjustable bullet feet on the front and flanged feet on the rear for securing to the floor. Boiler controls shall include an on/off power switch with indicator light, automatic water level, pressure gauge, water gauge glass, pressure control with pressure safety control, safety relief valve, cathodic protector and CSD-1 secondary low water cut off.

Boiler and kettle shall be ASME code stamped and National Board registered. Provide options and accessories as indicated.

WATER SUPPLY:

Water quality is a major factor affecting the performance of your steamer. If you are unsure of water quality, consult a local water treatment specialist and have the water analyzed. Your water supply must be within these general guidelines:

Total dissolved solids: Less than 60 PPM Total alkalinity: Less than 20 PPM
Silica: Less than 13 PPM Chlorine: Less than 1.5 PPM
pH Factor: 7.0 - 8.5

Water which fails to meet these standards should be treated by installation of a water conditioner. Failure or malfunction of this steamer due to poor water quality is not covered under warranty. Appliance is to be installed with backflow protection in accordance with Federal, State or Local codes.

NOTE: The company reserves the right to make substitutions of components without prior notice.

ELECTRICAL CHARACTERISTICS

kW	Phase	Amps per Line					
		208V	220V	240V	380V	415V	480V
42	3	116.6	110.2	101	63.8	58.4	50.5
48*	3	N/A	N/A	115.5	72.9	66.8	57.8

*Optional

SHIPPING INFORMATION:

Approx. Weight:
SB-6E-6-6k 910 lbs. (412 kg)
SB-10E-6-6k 950 lbs. (430 kg)

BLODGETT

www.blodgett.com 44 Lakeside Avenue, Burlington, VT 05401 • Phone: (802) 658-6600 • Fax: (802) 864-0183