



Project _____

Item No. _____

Quantity _____

All data is shown per oven section, unless otherwise indicated.

TABLES & STANDS

Tables & Stands For Steamers, Kettles & Braising Pans

KETTLE TABLES



Stainless steel construction satin finish

DIMENSIONS ARE IN INCHES [MM].

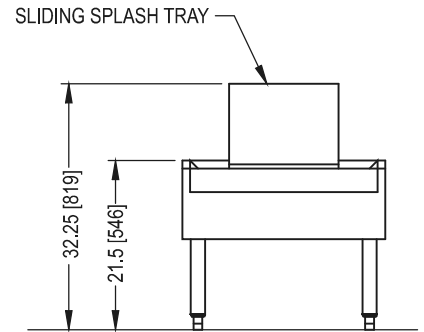
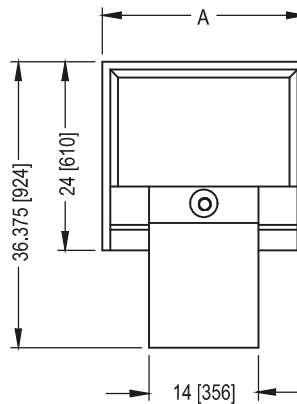

	26 INCH	40 INCH	50 INCH	64 INCH	80 INCH
A	26 [660]	40 [1016]	50 [1270]	64 [1626]	80 [2032]

TOP VIEW



STEAMER STANDS



Shown with ST-3E and steam pans

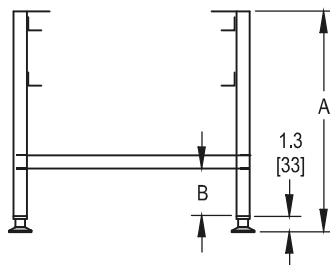

FRONT VIEW

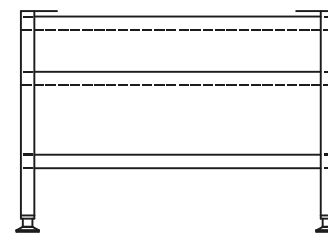

SIDE VIEW

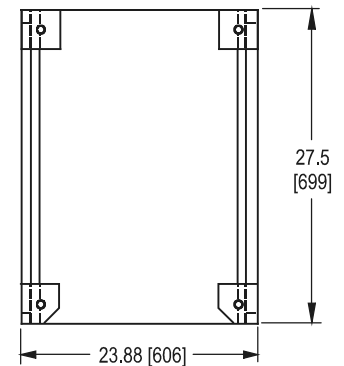

TOP VIEW

DIMENSIONS ARE IN INCHES [MM]

	18 INCH	28 INCH	34 INCH
A	18.13 [460]	29.13 [740]	34.13 [867]
B	4.375 [111]	6.75 [171]	6.75 [171]

BLODGETT OVEN COMPANY

www.blodgett.com

44 Lakeside Avenue, Burlington, VT 05401 • Phone: (802) 658-6600 • Fax: (802) 864-0183



TABLES & STANDS

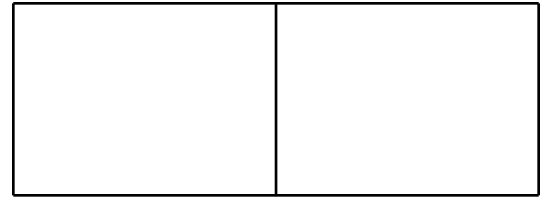

APPROVAL/STAMP

STAND WITH SLIDING SHELF FOR KETTLES AND BRAISING PANS



Stainless steel construction satin finish

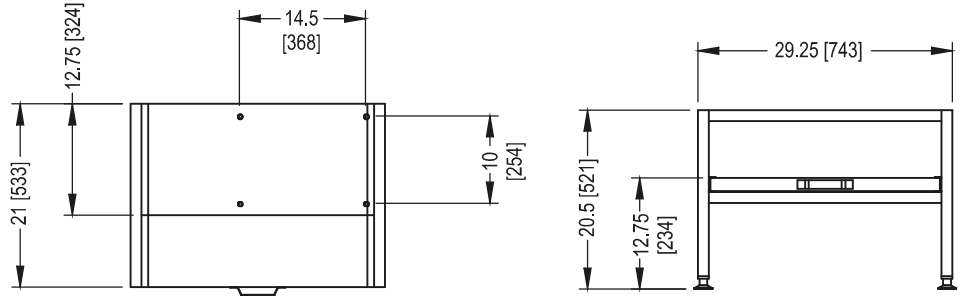

DIMENSIONS ARE IN INCHES [MM]



STAND WITH SLIDING DRAWER & DRAIN CONNECTION FOR KETTLES AND BRAISING PANS



Stainless steel construction satin finish

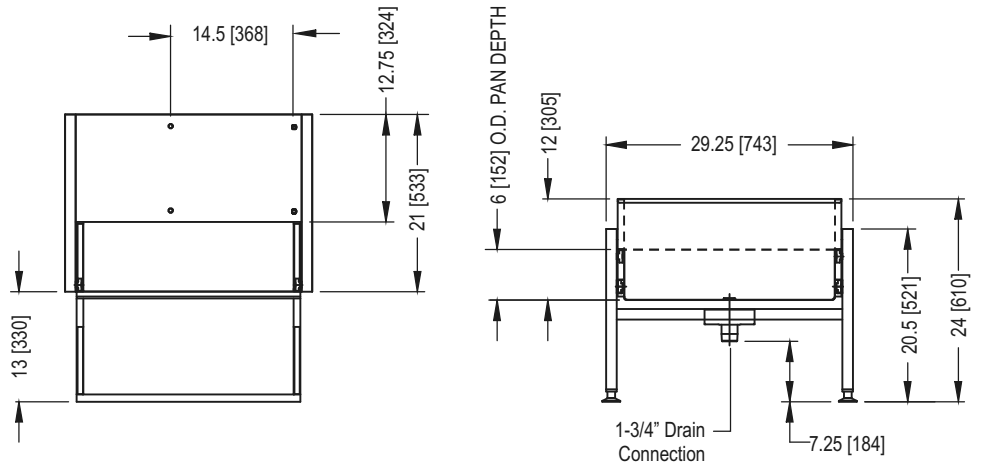

DIMENSIONS ARE IN INCHES [MM]



NOTE: The company reserves the right to make substitutions of components without prior notice

BLODGETT OVEN COMPANY

www.blodgett.com

44 Lakeside Avenue, Burlington, VT 05401 • Phone: (802) 658-6600 • Fax: (802) 864-0183