



DS-SC

Convection Steamer on an Cabinet Base Operating on Direct Steam



6DS-SC shown

OPTIONS AND ACCESSORIES
(AT ADDITIONAL CHARGE)
 Flange mounting feet

Project _____
Item No. _____
Quantity _____

- Model 6DS-SC (6 pan convection steamer operating on direct steam)
- Model 10DS-SC (10 pan convection steamer operating on direct steam)

CONSTRUCTION

- Stainless steel construction
- Stainless steel doors with strong continuous hinge and are field reversible for left or right swing
- Insulated doors have a one piece, replaceable seal
- Easy open handle and latch provide positive lock and seal when the door is pushed or slammed shut
- Hidden magnetic door switch cuts power to blower and steam flow to that cavity, when the door is opened
- Pan support racks shall be polished stainless steel and removable for easy cleaning
- Wide drip sink with condensate drain is positioned under cavity doors
- 24" wide cabinet base shall have stainless steel frame with all stainless steel top deck, removable access door, with side and rear panels.
- Front and rear legs shall have adjustable bullet feet

OPERATION

- Steamer cavity controls are mounted on the front panel for easy access
- Separate ON-OFF/60 minute timer control with constant steam setting, for each steamer cavity.
- Cabinet mounted power- ON switch activates steamer electronics
- Each steamer cavity has a powerful side mounted blower, which increases steam velocity and provides efficient steam distribution throughout cavity and between loaded pans.
- Requires a steam sources that delivers food safe steam at a minimum of 52 lbs. per hour (6DS-SC) or 88 lbs. per hour (10DS-SC), at a maximum working pressure of 15 PSI.

CAPACITY

Pan Size	6DS-SC	10DS-SC
12" x 20" x 1"	12	20
12" x 20" x 2.5"	6	10
12" x 20" x 4"	4	6

STANDARD FEATURES

- One year parts and labor warranty*

* For all international markets, contact your local distributor.



DS-SC CONVECTION STEAMER

BLODGETT

44 Lakeside Avenue, Burlington, VT 05401
Toll Free: (800) 331-5842 • Phone: (802) 860-3700 • Fax: (802) 864-0183



DS-SC CONVECTION STEAMER



APPROVAL/STAMP

NOTES:

1. Drain connection 1-1/4" NPT (includes steamers & condensate spray)
2. Cold water supply 3/8" NPT (for condensate spray)
3. Electrical connection 7/8" dia hole (ref 1/2" conduit knock-out)
4. Steam connection 1/2" NPT, see below for pressure requirements. Steam must be clean and suitable for food contact.
5. Dimensions are in inches (mm).

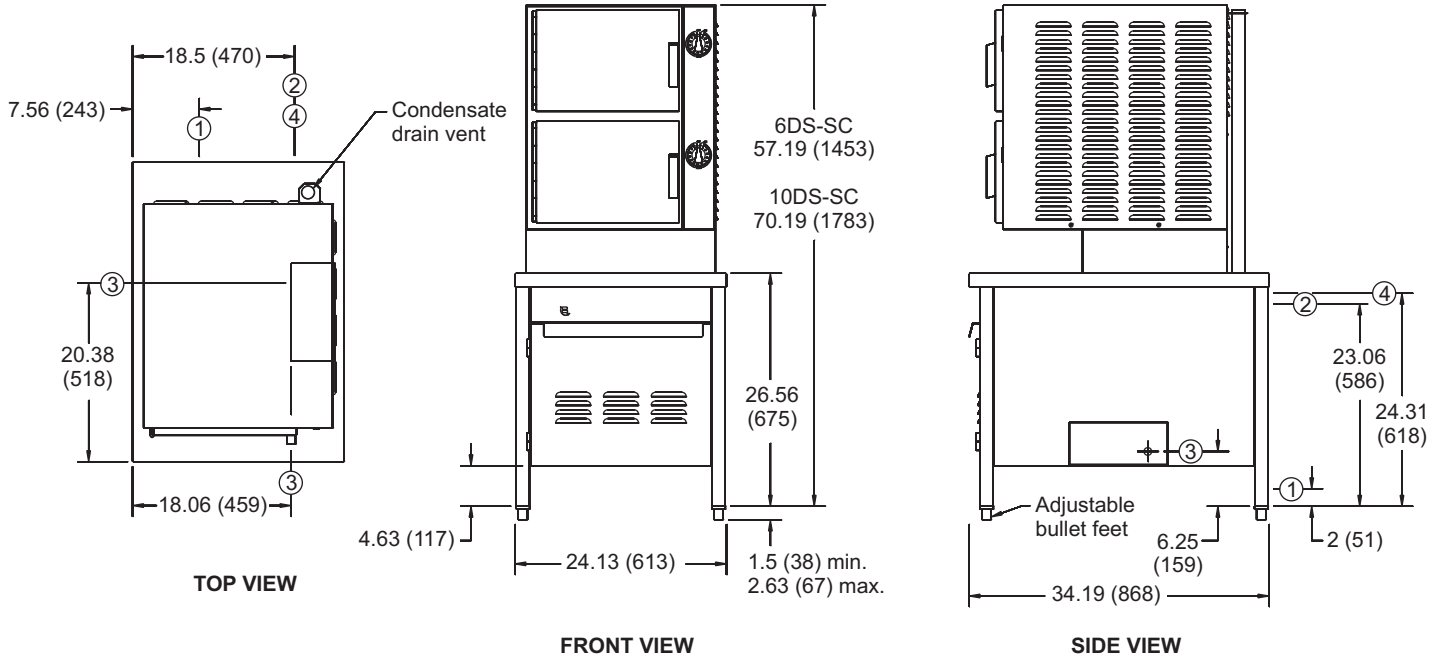

SHORT FORM SPECIFICATIONS

Provide Blodgett model 6DS-SC (6 pan) OR 10DS-SC (10 pan) pressureless steamer with gas heated pressure boiler mounted in 24" wide cabinet base. designed for operation with remote source food safe direct steam and mounted on 24" wide cabinet base. All stainless steel construction with two independent steamer chambers, each with powerful blower to circulate steam within cavity and individual 60 minute timer with constant steam setting. Doors are insulated, field reversible, with easy open latch and hidden magnetic door switch. Drip sink with condensate drain is provided under cavity doors. Three (2-1/2" deep) pan capacity per chamber. Cabinet base has stainless steel frame, all stainless steel exterior with removable access door and adjustable bullet feet. Provide options and accessories as indicated.

WATER SUPPLY:

Water quality is a major factor affecting the performance of your steamer. If you are unsure of water quality, consult a local water treatment specialist and have the water analyzed. Your water supply must be within these general guidelines:

Total dissolved solids: Less than 30 PPM Total alkalinity: Less than 20 PPM
 Silica: Less than 13 PPM Chlorine: Less than 1.5 PPM
 pH Factor: 7.0 - 9.0

Water which fails to meet these standards should be treated by installation of a water conditioner. Failure or malfunction of this steamer due to poor water quality is not covered under warranty.

WATER & DRAIN CONNECTIONS:

Drain 1-1/4" NPT free venting drain
 Cold Water 3/8" NPT cold water supply line
 Appliance is to be installed with backflow protection in accordance with Federal, State or Local codes.

STEAM CONNECTIONS:

1/2" NPT inlet for incoming steam
 6DS-SC 52 lbs/hour at 15 psi maximum
 10DS-SC 88 lbs/hour at 15 psi maximum

POWER SUPPLY:

115 VAC, 1 phase, 60 hz, 5 amp service with 4 amp maximum load

SHIPPING INFORMATION:

Approx. Weight:
 6DS-SC 410 lbs. (186 kg)
 10DS-SC 490 lbs. (223 kg)

NOTE: The company reserves the right to make substitutions of components without prior notice.

BLODGETT

44 Lakeside Avenue, Burlington, VT 05401 • Toll Free: (800) 331-5842 • Phone: (802) 860-3700 • Fax: (802) 864-0183