



SC-DS

Convection Steamer on an Cabinet Base Operating on Direct Steam



SC-6DS shown

OPTIONS AND ACCESSORIES

(AT ADDITIONAL CHARGE)

- 36" (914 mm) wide cabinet base for SC-6DS and SC-10DS
- Stainless steel frame
- Stainless steel rear panel
- Spray and rinse assembly
- Ball float trap
- Load compensating timer
- Correctional package
- One year extended warranty

CAPACITY

- Model SB-6DS is comprised of two 3 pan compartments
- Model SB-10DS is comprised of two 5 pan compartments
- Model SB-16DS is comprised of two 8 pan compartments

Project _____

Item No. _____

Quantity _____

- Model SC-6DS (6 pan convection steamer operating on direct steam)
- Model SC-10DS (10 pan convection steamer operating on direct steam)
- Model SC-16DS (16 pan convection steamer operating on direct steam)

STEAMER EXTERIOR CONSTRUCTION

- 304 #4 finish stainless steel
- Welded stainless steel door with removable inner stainless steel liner
- Full perimeter door gasket
- Positive lock and seam mechanism with spring release on door
- Stainless steel control housing
- One piece welded 316 stainless steel cooking chamber
- Coved corners
- Stainless steel pan supports
- Stainless steel drip trough integrally connected to drain

CABINET BASE CONSTRUCTION

- 24" (610 mm) wide cabinet base for SC-6DS and SC-10DS
- 36" (914 mm) wide cabinet base for SC-16DS
- Full perimeter painted angle iron frame
- Reinforced steamer mountings
- Stainless steel exterior
- Hinged door(s) with magnetic latch
- 6" (152 mm) stainless steel legs with adjustable bullet feet on front and adjustable flanged feet on rear for securing to floor

OPERATION

- Pressureless steam operation
- Separate controls for each compartment
- Controls accessible through removable side panel
- On/off power switch with indicator light
- Ready indicator light
- Cooking indicator light
- 60 minute electric timer with audible alarm to signal end of cook cycle
- Steam flow to the cooking chamber is cut off when the door is opened during the cooking cycle and reactivated when the door is closed

STANDARD FEATURES

- 115 VAC, 1 phase, 60 Hz for controls
- Electromechanical controls
- Steam condensing drain
- One year parts and labor steamer warranty*
- Five year limited steamer door warranty*

* For all international markets, contact your local distributor.

SC-DS CONVECTION STEAMER



BLODGETT OVEN COMPANY

www.blodgett.com

44 Lakeside Avenue, Burlington, VT 05401 • Phone: (802) 658-6600 • Fax: (802) 864-0183



SC-DS CONVECTION STEAMER



APPROVAL/STAMP

DIMENSIONS ARE IN INCHES [MM]

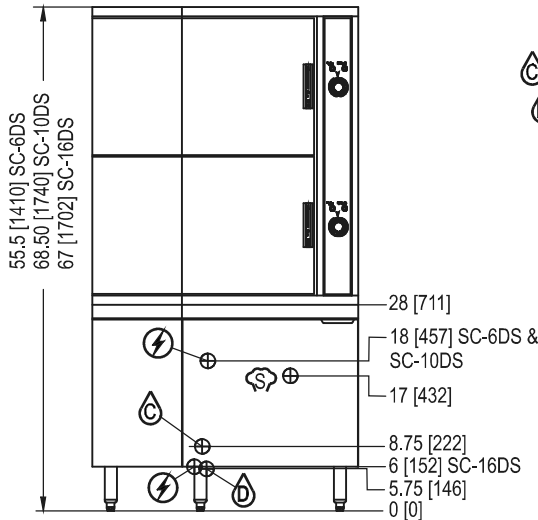

REAR FLANGED FOOT DETAIL
2 EQUALLY SPACED Ø7/16" [11mm] HOLES
ON 2.5 [63] B.C.

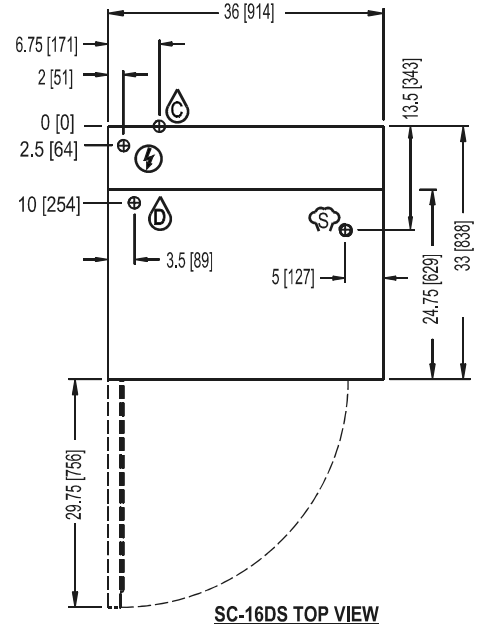
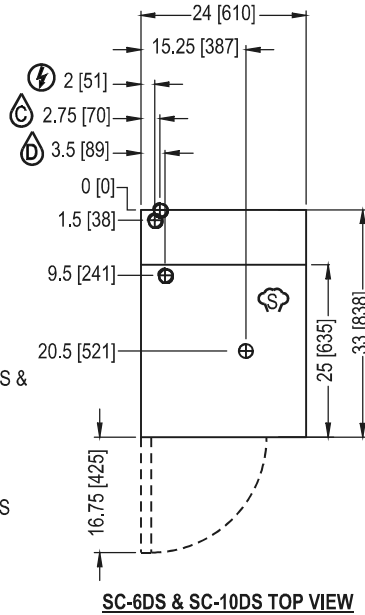

SHORT FORM SPECIFICATIONS

Provide Blodgett model SC-6DS (6 pan), SC-10DS (10 pan) or SC-16DS (16 pan) convection steamer operating on direct steam. The SC-6DS and SC-10DS shall be mounted on a 24" wide base (an optional 36" base is available). The SC-16DS shall be mounted on a 36" wide base. The SC-6DS is comprised of two 3 pan compartments. The SC-10DS is comprised of two 5 pan compartments. The SC-16DS is comprised of two 8 pan compartments. Unit shall be constructed of satin finish 304 stainless steel with a one piece welded stainless steel cooking chamber with coved corners. The door shall have a removable inner liner of stainless steel with full perimeter gasket seal, an outer liner of one-piece all welded stainless steel, and a positive lock and seal mechanism with spring release. Each compartment shall have removable stainless steel pan supports. A stainless steel drip trough integrally connected to collect and drain condensate with the doors open. The control housing shall be constructed of stainless steel with a full access removable panel. The controls shall include an on/off power switch with LED, a ready indicator light, cooking indicator light, and a 60 minute electric timer with audible alarm that signals the end of the cook cycle. Steam flow to the compartment shall be cut off when the door is opened during the cook cycle and shall be reactivated when the door is closed. The cabinet base shall have full perimeter painted angle iron frame, reinforced counter, stainless steel exterior, hinged doors and 6" (152 mm) stainless steel legs with adjustable bullet feet on the front and flanged feet on the rear for securing to floor. Provide options and accessories as indicated.

WATER SUPPLY:

Water quality is a major factor affecting the performance of your steamer. If you are unsure of water quality, consult a local water treatment specialist and have the water analyzed. Your water supply must be within these general guidelines:

Total dissolved solids: Less than 60 PPM Total alkalinity: Less than 20 PPM
Silica: Less than 13 PPM Chlorine: Less than 1.5 PPM
pH Factor: 7.0 - 8.5

Water which fails to meet these standards should be treated by installation of a water conditioner. Failure or malfunction of this steamer due to poor water quality is not covered under warranty.

WATER & DRAIN CONNECTIONS:

Drain 2" (51mm) IPS piped to open floor drain. No solid connection.
24" length before open air opening (no bends or elbows)
Cold Water 3/8" (10mm) tubing at 25-50 PSI (170-345 kPa)
Appliance is to be installed with backflow protection in accordance with Federal, State or Local codes.

STEAM CONNECTIONS:

3/4" inlet for incoming steam at a minimum of 80 lbs/hour at 10 psi (36kg/hr at 69 kPa).

POWER SUPPLY:

1/2" (13 mm) conduit connection to controls. 2 amps per compartment

SHIPPING INFORMATION:

Approx. Weight:	w/24" base	w/36" base
SC-6DS	500 lbs. (227 kg)	550 lbs. (249 kg)
SC-10DS	600 lbs. (272 kg)	650 lbs. (295 kg)
SC-16DS	n/a	750 lbs. (340 kg)

NOTE: The company reserves the right to make substitutions of components without prior notice.

BLODGETT OVEN COMPANY

www.blodgett.com

44 Lakeside Avenue, Burlington, VT 05401 • Phone: (802) 658-6600 • Fax: (802) 864-0183