



SC-E

Electric Convection Steamer
on a 24" Modular Cabinet Base



SC-7E shown

OPTIONS AND ACCESSORIES

(AT ADDITIONAL CHARGE)

- Voltage options
 - 220 VAC, 3 phase, 60 hz
 - 240 VAC, 3 phase, 60 hz
 - 220/380, 3 phase, 60 hz, 4 wire
 - 240/415, 3 phase, 60 hz, 4 wire
 - 380 VAC, 3 phase 60 hz
 - 415 VAC, 3 phase, 60 hz
 - 480 VAC, 3 phase, 60 hz
 - 600 VAC, 3 hz, 60 hz
- 12" x 20" (305 x 508 mm) pan guides for cabinet base
- 120 minute timer
- Correctional package
- One year extended warranty

CAPACITY

- Model SC-7E is comprised of one 3 pan steamer compartment and one 4 pan steamer compartment
- Model SC-10E is comprised of two 5 pan steamer compartments

Model	Pan Depth			
	1"	2.5"	4"	6"
SC-7E	14	7	4	2
SC-10E	20	10	6	4

Project _____

Item No. _____

Quantity _____

- Model SC-7E (7 pan electric convection steamer)
- Model SC-10E (10 pan electric convection steamer)

EXTERIOR CONSTRUCTION

- 304 satin finish stainless steel
- Welded stainless steel door with removable inner stainless steel liner
- Full perimeter door gasket
- Positive lock and seam mechanism with spring release on door
- Stainless steel control housing

INTERIOR CONSTRUCTION

- One piece welded 316 stainless steel cooking chamber
- Coved corners
- Stainless steel pan supports
- Stainless steel drip trough integrally connected to drain

OPERATION

- Pressureless steam operation
- Delime mode power setting
- Automatic generator blowdown
- Separate controls for each compartment
- Full access removable control panel
- Illuminated on/off/delime power switch
- Ready indicator light
- Cooking indicator light
- 60 minute electric timer with audible alarm to signal end of cook cycle
- Solid state generator controls
- Steam flow to the cooking chamber is cut off when the door is opened during the cooking cycle and reactivated when the door is closed

STANDARD FEATURES

- Delimiting port located in the rear of the unit for each generator
- Delimiting mode power setting
- Electromechanical controls
- Split water connections
- 24" wide cabinet base with hinged door and 6" (152 mm) legs
- Standard voltage options
 - 208 VAC, 3 phase, 60 hz
 - 240 VAC, 3 phase, 60 hz
- One year parts and labor steamer warranty*
- Five year limited steamer door warranty*

* For all international markets, contact your local distributor.



SC-E CONVECTION STEAMER

BLODGETT OVEN COMPANY

www.blodgett.com

44 Lakeside Avenue, Burlington, VT 05401 • Phone: (802) 658-6600 • Fax: (802) 864-0183



SC-E CONVECTION STEAMER



APPROVAL/STAMP

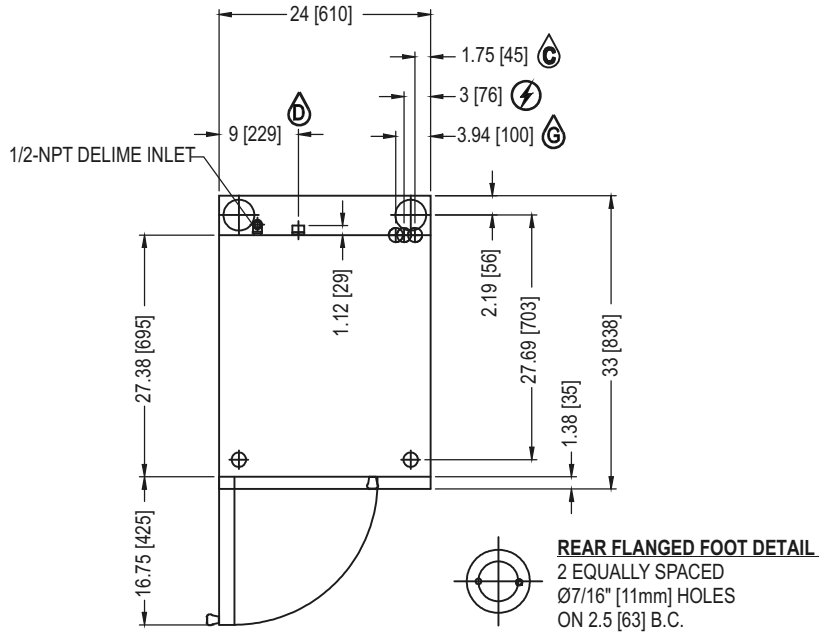
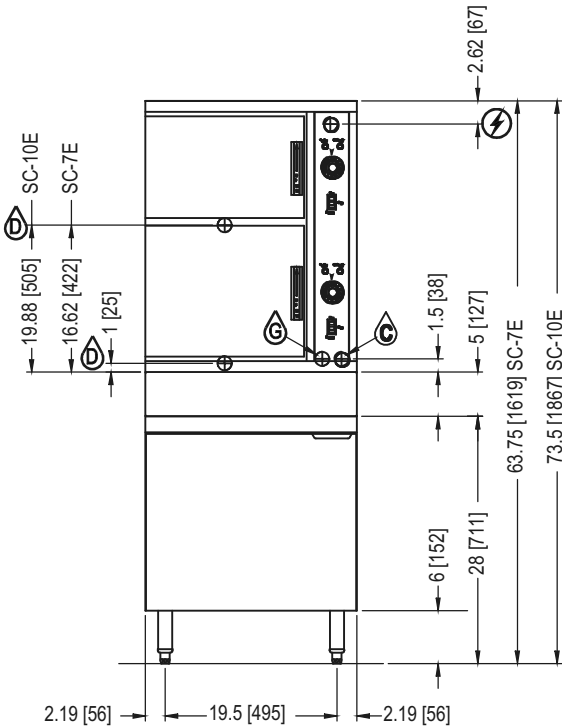

SHORT FORM SPECIFICATIONS

Provide Blodgett model SC-7E (7 pan), SC-10E (10 pan) convection steamer with electric steam generator mounted on a 24" wide cabinet base. The SC-7E is comprised of one 3 pan compartment on top of one 4 pan compartment. The SC-10E is comprised of two 5 pan compartments. Each compartment shall have its own steam generator. Unit shall be constructed of satin finish 304 stainless steel with a one piece 316 welded stainless steel cooking chamber with covered corners. The door shall have a removable inner liner of stainless steel with full perimeter gasket seal, an outer liner of one-piece all welded stainless steel, and a positive lock and seal mechanism with spring release. Each compartment shall have removable stainless steel pan supports and a stainless steel drip trough integrally connected to collect and drain condensate with the doors are open. The control housing shall be constructed of stainless steel with a full access removable panel. The controls shall include an illuminated on/off/delime power switch, a ready indicator light, cooking indicator light, 60 minute electric timer with audible alarm that signals the end of the cook cycle, solid state generator controls and delime mode power setting. Steam flow to the compartment shall be cut off when the door is opened during the cook cycle and shall be reactivated when the door is closed. Unit shall have a delimiting port located in the rear. The unit shall have an automatic generator blow down and split water connections. Provide options and accessories as indicated.

WATER SUPPLY:

Water quality is a major factor affecting the performance of your steamer. If you are unsure of water quality, consult a local water treatment specialist and have the water analyzed. Your water supply must be within these general guidelines:

- Total dissolved solids: Less than 60 PPM
- Total alkalinity: Less than 20 PPM
- Silica: Less than 13 PPM
- Chlorine: Less than 1.5 PPM
- pH Factor: 7.0 - 8.5

Water which fails to meet these standards should be treated by installation of a water conditioner. Failure or malfunction of this steamer due to poor water quality is not covered under warranty.

WATER & DRAIN CONNECTIONS:

- Drain 1" (25mm) IPS piped to open floor drain. No solid connection. 24" length before open air gap opening (no bends or elbows)
- Cold Water 3/8" (10mm) tubing at 25-50 PSI (170-345 kPa)

Appliance is to be installed with backflow protection in accordance with Federal, State or Local codes.

NOTE: The company reserves the right to make substitutions of components without prior notice.

MAXIMUM INPUT:

- SC-7E 17.5 kW
- SC-10E 24kW standard, 30 kW (optional)

POWER CONNECTION:

1-1/8" (29mm) hole for electrical connection

AMPS PER LINE						
kW	Phase	208V	220V	240V	380V	480V
17.5	3	48.6	45.9	42.1	26.6	21.1
24	3	66.6	63	57.8	36.5	28.9
30	3	83.3	78.7	72.2	45.6	36.1

SHIPPING INFORMATION:

- Approx. Weight:**
- SC-7E 400 lbs. (181 kg)
- SC-10E 450 lbs. (204 kg)

BLODGETT OVEN COMPANY

www.blodgett.com 44 Lakeside Avenue, Burlington, VT 05401 • Phone: (802) 658-6600 • Fax: (802) 864-0183