



901

Single & Double Gas Deck Oven



OPTIONS AND ACCESSORIES

(AT ADDITIONAL CHARGE)

- **Flexible gas hose with quick disconnect and restraining device**
 - 36" (914 mm)
 - 48" (1219mm)
- Black legs with casters
- Stainless steel crown angle trim
- Vent kit
- Double connector for stacking
- QHT Rokite deck 1-1/2" (38.1mm) thick pizza type deck
- Steam jets
- FDTH 300° to 650° temperature thermostat

OPTIONS AND ACCESSORIES

(AT NO ADDITIONAL CHARGE)

- Centigrade dial, 100°C to 300°C

Project _____

Item No. _____

Quantity _____

Ovens consist of basic sections and are a complete and separate unit capable of operating alone or in combination. All data is shown per oven section, unless otherwise indicated. All data is shown per oven section, unless otherwise indicated.

Refer to operator manual specification chart for listed model names.

EXTERIOR CONSTRUCTION

- Full angle iron frame
- Stainless steel front, top, sides and back
- Counterbalanced doors with concealed hinges
- Heavy chrome plated tubular steel door handle
- 27-1/2" (699mm) stainless steel legs (for single units)
- 7" (178mm) stainless steel legs (for double units)
- Burner doors open easily for ignition, cleaning or adjustment, without removal of any fastenings
- Vitreous fiber insulation at top, back, sides, bottom and doors

INTERIOR CONSTRUCTION

- 33" x 22" x 12" (8387mm x 559mm x 305mm) oven compartment interior
- Aluminized steel baking compartment liner
- Aluminized steel combustion chamber
- Steel deck supported by an angle iron frame
- 12 gauge (3.02mm) press-formed, reinforced and flanged aluminized steel deck

OPERATION

- Free-floating, easily removable duplex-tube burner
- Removable fixed orifices on main and pilot burner
- Main gas valve, temperature control valve and safety pilot valve fully within section body and are accessible through a covered and ventilated compartment in front.
- Air mixers with adjustable air shutters and locking device
- Liquid pressure thermostat with temperature control range of 200°F (93°C) to 500°F (288°C)

STANDARD FEATURES

- Steel oven deck
- Fahrenheit dial 200°F to 500°F
- Two year parts and one year labor warranty
- Five year limited oven door warranty*

** For all international markets, contact your local distributor.*

NOTE: The company reserves the right to make substitutions of components without prior notice

901 - SINGLE/DOUBLE





901 DECK OVEN

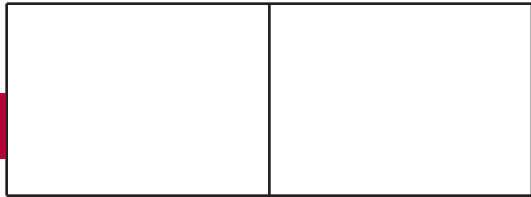

APPROVAL/STAMP

DIMENSIONS ARE IN INCHES (MM)

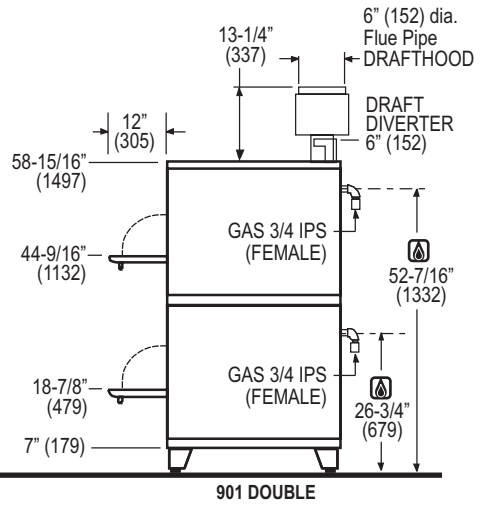
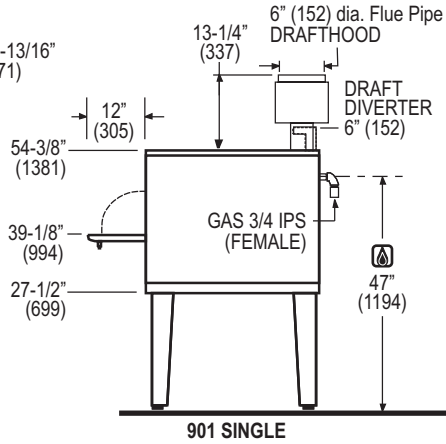
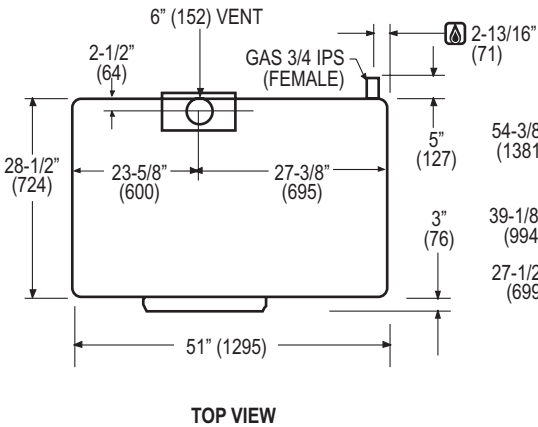

SHORT FORM SPECIFICATIONS Provide Blodgett (single/double) deck oven, model 901. Construction shall be welded stainless steel front, top, back and sides, and shall be fully insulated on all sides. Oven shall be supported by formed adjustable legs. Door(s) shall be counterbalanced (no springs) with concealed hinges and chrome plated tubular steel handles. Separate burner door provided for ignition, cleaning and adjustment. Each baking compartment shall be 33" W x 12" H x 22" D and shall be lined with aluminized steel. Deck shall be 11 gauge press-formed, reinforced and flanged steel. Unit shall be gas heated by a free-floating, easily removable, duplex-type burner controlled by a liquid pressure thermostat with range of 200°F to 500°F. Each compartment provided with flue vent. Provide with two year limited parts and one year labor warranty. Provide with options and accessories as indicated.

DIMENSIONS

Floor space	51" (1495mm) wide x 30" (762mm) deep
Cooking Compartment (per section)	
Size	33" (838mm) W x 12" (305mm) H x 22" (559mm) D
Area	5.04 sq. ft. (0.87m ²)

SECTION DETAILS

	Single	Double
Number of section	1	2
Number of controls	1	2
Number of compartments	1	2

PRODUCT CLEARANCE

From combustible and non-combustible construction

6" (152 mm)

PAN CAPACITIES

	Single	Double
10" (254mm) pie tins:	6	12
18" x 26" (457mm x 660mm) bun pans	1	2
9-1/2" x 5" (241mm x 127mm) bread pans	12	24
9" x 7" (228mm x 178mm) roll pans	9	18
19" x 4" (483mm x 102mm) pullman pans	8	16
13" x 16-1/2" (330mm x 419mm) cup tins	2	4
20" x 28" (508mm x 711mm) roast pans	1	2
No. 200 pans (324mm x 527mm)	2	4
#1 bean pot	15	30
#2 bean pot	8	16
#3 bean pot	6	12

GAS SUPPLY (per section)

	3/4" NPT
Inlet Pressure	
Natural Gas	7.0" W.C. min. – 10.5" W.C. max.
Propane	11.0" W.C. min. – 13.0" W.C. max.

Manifold Pressure

Natural Gas	5" W.C.
Propane	10" W.C.

MAXIMUM INPUT

22,000 BTU/hr per oven section

MINIMUM ENTRY CLEARANCE

Uncrated	23-1/4" (591mm)
Crated	37" (940mm)

SHIPPING INFORMATION

Approx. Weight

Single	410 lbs. (186kg)
Double	820 lbs. (372kg)

Crate Size

65" (1651mm) 37" (940mm) 46.5" (1181mm)
(2 crates required for double)